

SERVICE MANUAL

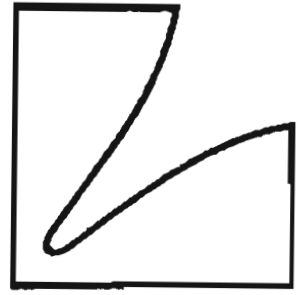

LUXMAN STEREO CASSETTE DECK

K-15

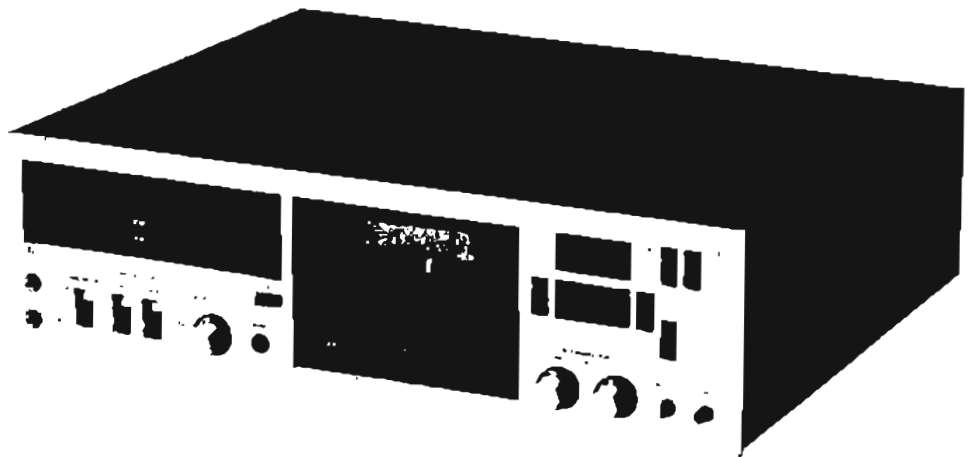

SPECIFICATIONS



• Heads:	Combination 3 heads Record/Playback: Erase:	sendust/sendust x 1 sendust x 1
• Drive Motor:	2 motors	
Capstan Drive:	FG servo motor	
Reel Drive:	Compact DC motor	
• Tape Drive:	Dual Capstan System	
• Operation:	Feather Touch Logic Control Operation	
• Amplifier:	Playback & Recording Amp.	DC amp configuration
• Wow & Flutter:	no more than 0.04% (W.R.M.S.)	
• Frequency Response:	20Hz ~ 18,000Hz (30Hz ~ 16,000Hz ± 3dB)	LH tape
	20Hz ~ 19,000Hz (30Hz ~ 17,000Hz ± 3dB)	CrO ₂ tape
	20Hz ~ 20,000Hz (30Hz ~ 18,000Hz ± 3dB)	METAL tape
• Signal-to-Noise Ratio:	better than 83dB (Dolby on)	LH tape
	better than 56dB (Dolby off)	LH tape
	better than 65dB (Dolby on)	CrO ₂ tape
	better than 58dB (Dolby off)	CrO ₂ tape
	better than 85dB (Dolby on)	METAL tape
	better than 58dB (Dolby off)	METAL tape
• Overall Distortion:	no more than 1.2% (LH tape, 1kHz, 0dB)	
• Input Sensitivity:	line: 100mV mic: 0.25mV (recommended microphone impedance 600 ohms ~ 10k ohms)	
• Output Level:	line: 580mV headphone: 1.5mW (8 ohms load)	
• Additional Features:	14 dot Fluorescent Peak Level Indicator with Peak Hold function, Digital Tape Counter, Bias Fine Control, Dolby NR System (with HX position), Automatic Program Repeat (A.P.R.) System, Timer Recording/Playback function, Monitor Circuit, Remote Control (available with optional remote control box.)	
• Power Consumption:	30W	
• Dimensions:	428(W) x 126(H) x 370(D)mm (17-1/4" x 4-9/16" x 14-9/16")	
• Weight:	Net 11.5kgs (25.3 lbs.) Gross 13.0kgs (28.6 lbs.)	

Specifications and appearance design subject to change without notice.

• NOISE REDUCTION CIRCUIT MADE UNDER LICENCE FROM DOLBY LABORATORIES. THE WORLD "DOLBY" AND THE DOUBLE-D SYMBOL ARE THE TRADE MARKS OF DOLBY LABORATORIES.

DESTINATION TABLE

MODEL K-15

Destination	SK	SK.L	SG	EK	EZ	EC	EJ
	Europe Asia	Sweden	England Austria New Zealand	Europe Asia	U. S. A.	Canada	Japan
Safety Standard	DEMKO BS SEV	SEMKO VDE	DEMKO BS SEV		UL LAA	CSA	EJA
Power Transformer	P - 0013						
Voltage Selector	P - 0014						
			Voltage Selector Plug		P2120 - A (A-0009)		
			Voltage Selector Socket		M1625 (A-0008)		
Power Switch	SDG5P - E (S - 0016)		SEMKO-Mark		SDG5P (S - 0014) UL.CSA-Mark		SDG1P (S-0033) 
Primary Fuse	T315 mA 250 V (SEMKO)				61M - 1A 250 V (UL.CSA)		 1A 250 V
Secondary Fuse	T315 mA 250V x3 T1.25 A 250Vx4						
Fuse PCB	PCM - 037 Seal-1370	PCM - 038	PCM - 037 Seal-1370		PCM - 037		
Fuse Holder	S - N5053 (B - 0004)				S - N5051 (B - 0005)		
Line Condenser	PME265MA447 - 4700P (C - 0028)				DE7100FZ472P125VAC (C - 0027)		
Power Cord	C - 2 - 4610 (A - 0016)	VRF-777 (A-0025)	C-2-4610 (A-0016)	UL.CSA VW-1 (A-0026)		 (A-0004)	
MIC.LIN VOL Knob	Knob Set - 3010				Knob Set - 3005		
OUTPUT VOL Knob	Knob Set - 3007		U. J		Knob Set - 3008		Other
Lever Switch Knob	Mold Knob - 1121				Mold Knob - 3009		

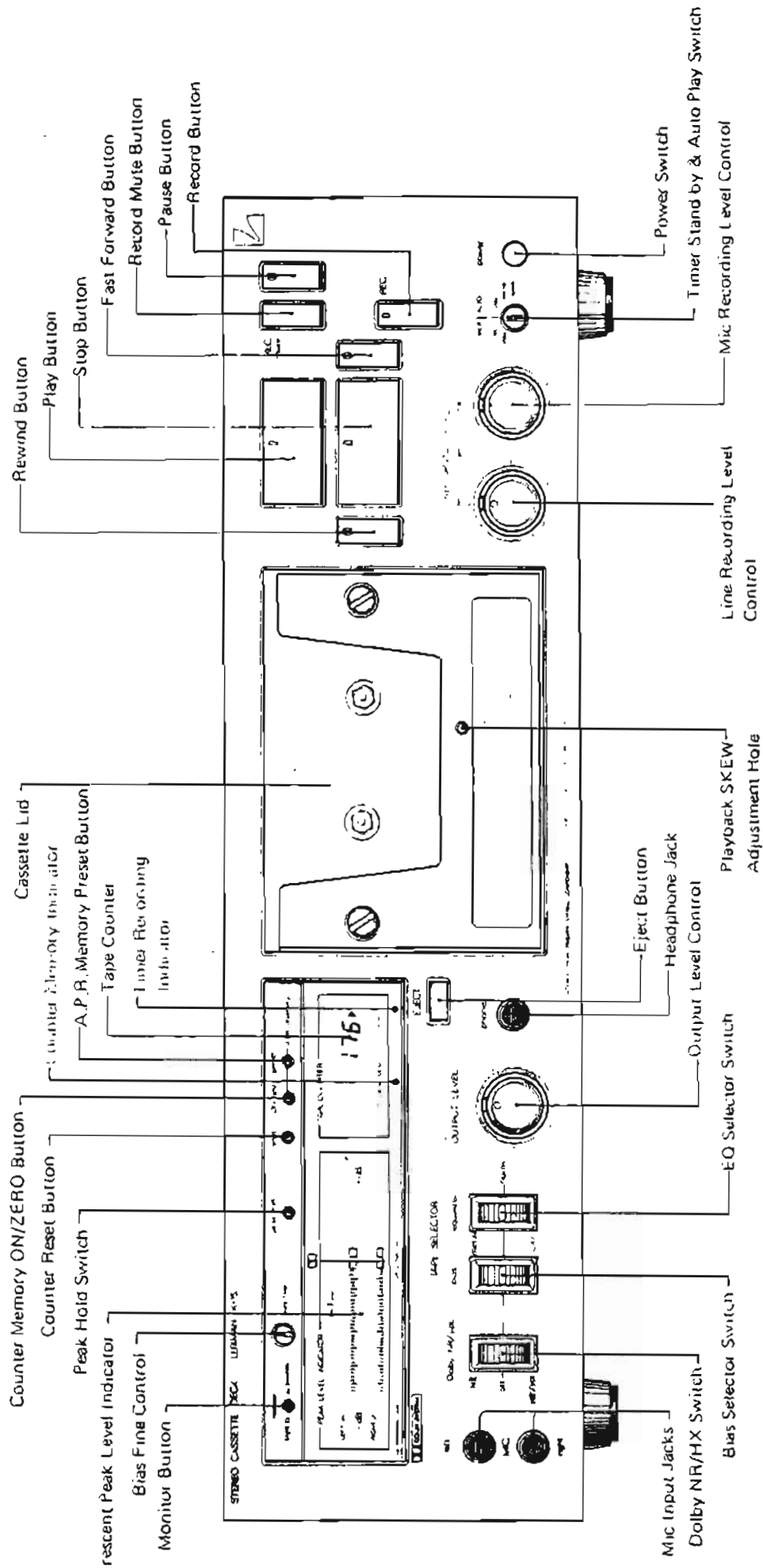

1.3

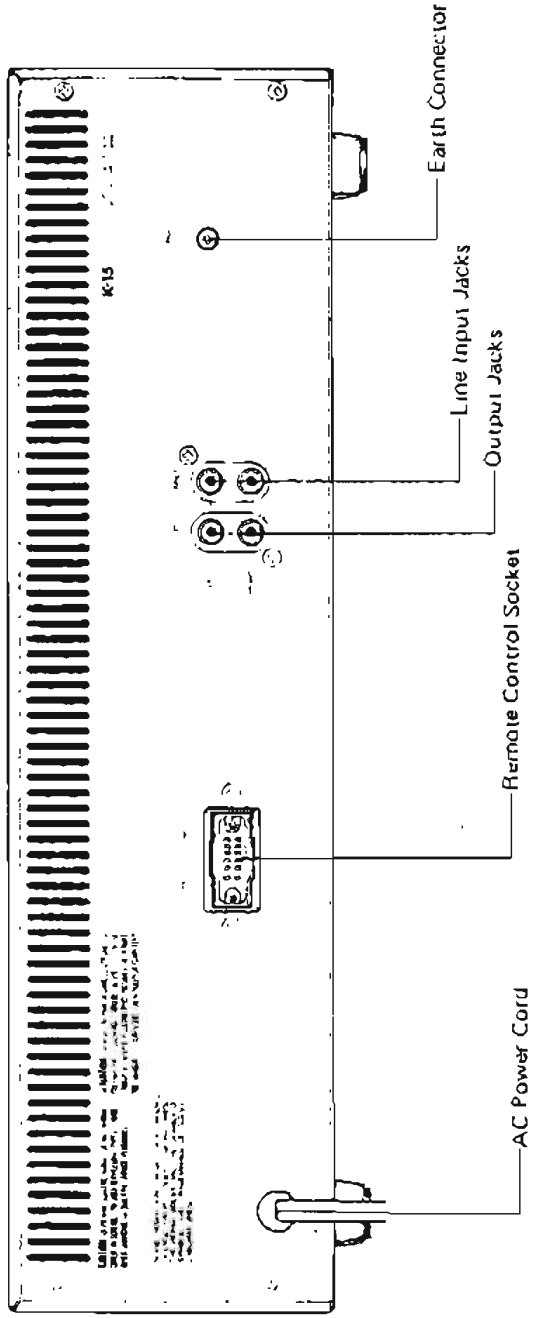

Adjustment Specifications

1. Scope of Description

These specifications are to illustrate in detail the adjustment procedures for the Cassette Deck K-15.

2. Test Instruments

Test instruments necessary for the adjustments are as follows:

- 1) Oscillator
- 2) Attenuator
- 3) AC voltmeter, 2ch
- 4) Frequency counter
- 5) Automatic distortion factor meter, 2ch
- 6) 1 KHz band pass filter

3. Playback Test Tapes

1) Azimuth adjustment : MTT-114, 10 KHz

2) Dolby level test : MTT-150, 400 Hz

3) Frequency response adjustment:

3,180 μ sec + 120 μ sec

MTT-216 (31.5 Hz - 14 KHz) or

MTT-215C (315 Hz, 10 KHz)

4) Frequency response test:

3,180 μ sec + 120 μ sec

MTT-216 or MTT-217L

(63 Hz, 315 Hz, 6.3 KHz, 10 KHz),

3,180 μ sec + 70 μ sec

MTT-316 (31.5 Hz - 14 KHz)

4. Recording Alignment Tapes

1) NORMAL position : TDK AC 222

2) CrO2 position : TDK AC 512

3) METAL position : TDK AC 702

5. Test Instrument Connections

1) Signal source impedance is 600 ohms.

2) Deck output load is 47 K-ohms.

3) Headphone output load is 8 ohms.

6. Decibel Definition

Zero dB is defined as 0.775 V.

7. Deck Controls

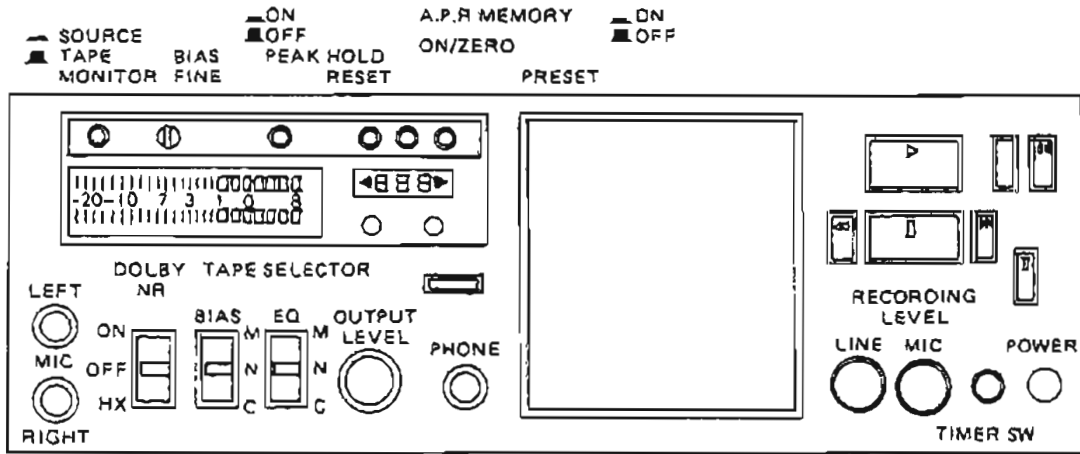

8. Adjusting and Test Points

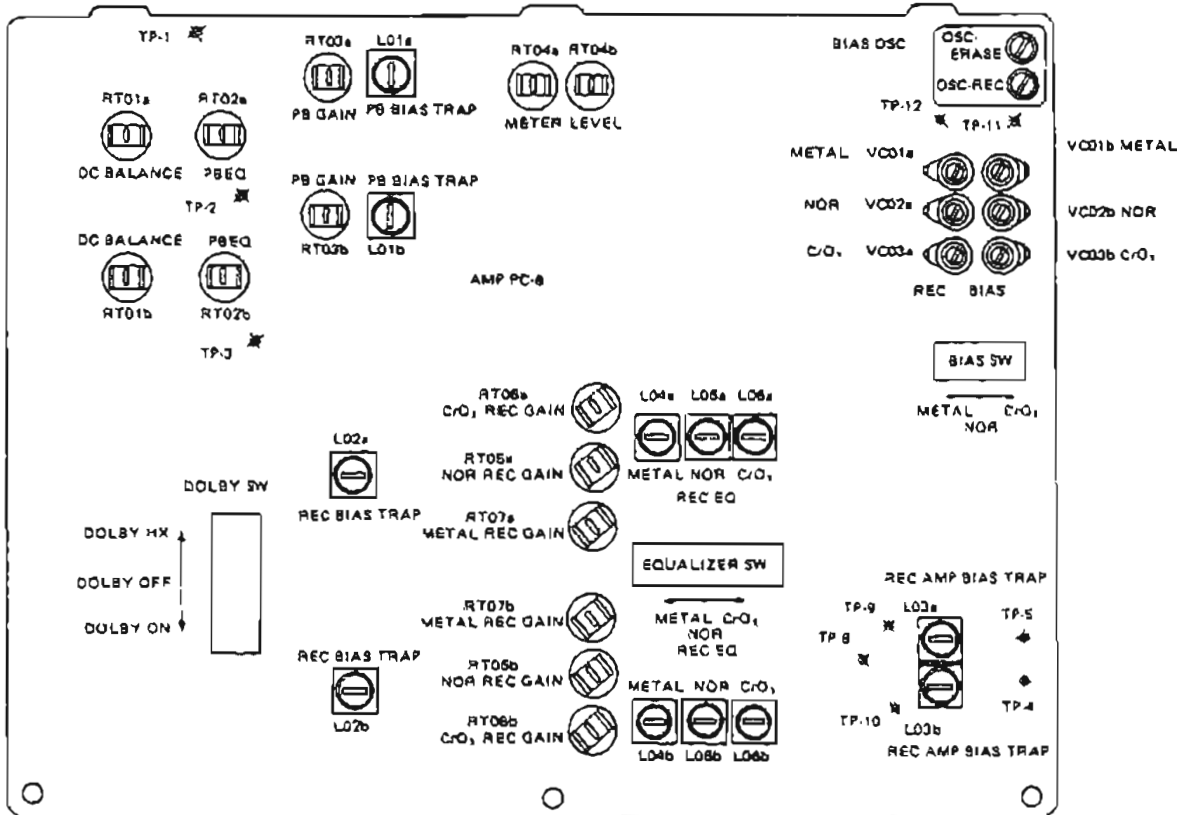

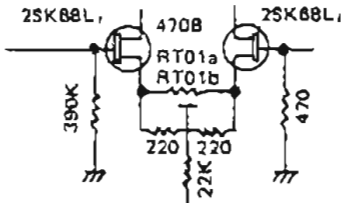
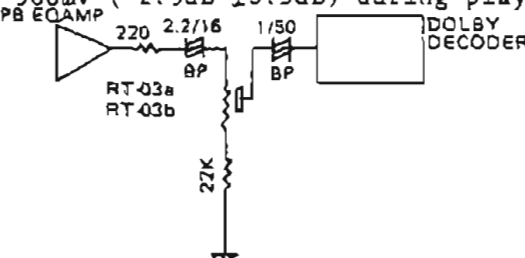
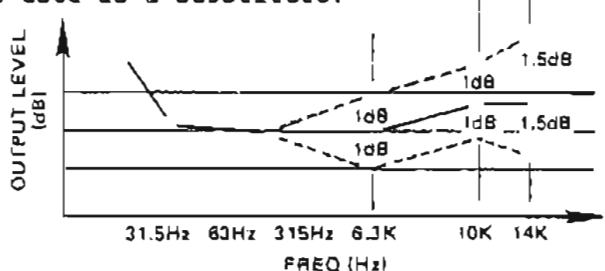
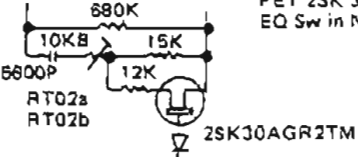
Adjustment and Check Items	Adjusting Procedure	Adjusting Point/Mode
Playback Equalizer, Amp, and DC Balance Adjustments	<p>Connect a DC oscillator, DC vacuum-tube volt-meter, or multi-meter to the test points, Lch (H) TP-1, Lch(E) TP-2, Rch(H) TP-3, Rch(E) TP-2, and adjust the semi-fixed resistors, Lch RT01a and Rch RT01b so that the drift center will fall within $\pm 50\text{mV}$. After all adjustments, check DC balance and adjust as necessary.</p> 	<p>[Adjusting Point]</p> <p>Lch RT01a Rch RT01b</p>
Playback Dolby Level Adjustment	<p>Set a Dolby level test tape MTT-150 (400Hz, 200nWb/m), and adjust the semi-fixed resistors, Lch RT03a and Rch RT03b so that the line output will reach 580mV ($-2.5\text{dB} \pm 0.5\text{dB}$) during playback.</p> 	<p>[Adjusting Point]</p> <p>Lch RT03a Rch RT03b</p> <p>[Mode]</p> <p>PLAY BUTTON ON OUTPUT VOL MAX MON SW TAPE EQ SW NOR DOLBY SW OFF</p>
Playback Frequency Response Adjustment (NOR MODE)	<p>Set a test tape MTT-215C (3,180μsec + 120μsec, 315Hz · 10KHz, -10dB), and adjust the semi-fixed resistors, Lch RT02a and Rch RT02b so that frequency response will be 0dB \pm 1dB up at 10KHz with 315Hz as a reference. Next, set a test tape MTT-216 (3,180μsec + 120μsec), and check to see that the f-response falls within the range shown in the graph. If the f-response falls outside the range, readjust the semi-fixed resistors. Note that low-frequency f-response should be 31.5Hz +4.0/-0 dB, 63-250Hz \pm 2.0dB for 315Hz. A test tape MTT-217L (3,180μsec + 120μsec, 315Hz, 10KHz, 6.3KHz, 63Hz) may be used as a substitute.</p>   <p>FET 2SK 30A is off with EQ Sw in NOR position.</p>	<p>[Adjusting Point]</p> <p>Lch RT02a Rch RT02b</p> <p>[Mode]</p> <p>PLAY BUTTON ON OUTPUT VOL MAX MON SW TAPE EQ SW NOR DOLBY SW OFF</p>

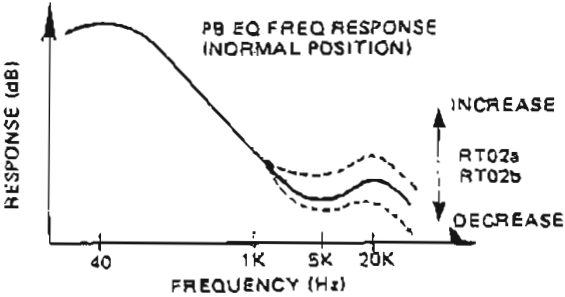
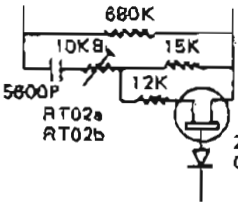
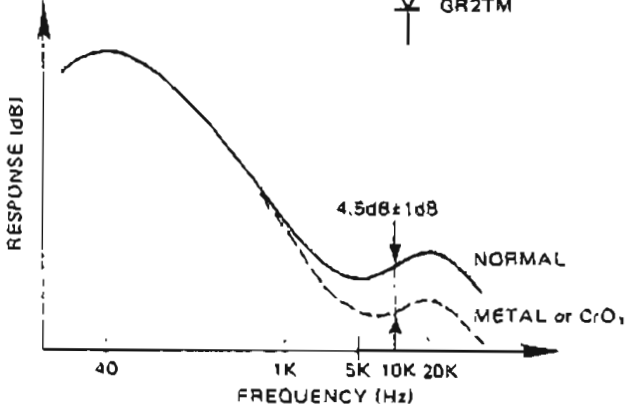
Adjustment and Check Items	Adjusting Procedure	Adjusting Point/Mode
		
<p>PB Frequency Response Check (CrO₂ or METAL position)</p>	<p>Set a test tape MTT-114 (3,180μsec + 120μsec, 10KHz, -10dB) and check to see that moving the EQ SW from NORMAL to METAL or CrO₂ will cause 10KHz output to decrease by 4.5dB ±1dB. A test tape MTT-215C (3,180μsec + 120μsec, 10KHz, 315Hz, -10dB) may be used as a substitute.</p> <div style="text-align: center;">  <p>FET 2SK 30A GR2TM is on with EQ Sw in CrO₂ or METAL position.</p> </div> 	<p>[Mode]</p> <p>PLAY BUTTON ON OUTPUT VOL MAX MON SW TAPE DOLBY SW OFF EQ SW NOR/CrO₂ or METAL</p>
<p>PB Muting Check</p>	<p>By playing back then stopping a blank tape, check to see that the line output will not produce any hiss and click.</p>	<p>[Mode]</p> <p>PLAY BUTTON ON/OFF OUTPUT VOL MAX MON SW TAPE EQ SW NOR DOLBY SW OFF</p>

Adjustment and Check Items	Adjusting Procedure	Adjusting Point/Mode
PB Noise Check	<p>Play back a blank tape and check to see that the S/N and hum levels fall within the specified range.</p> <p><u>Noise Level</u></p> <p>NORMAL position : -51.0dB or less METAL/CrO₂ position : -52.0dB or less</p> <p><u>Hum Level</u></p> <p>Hum level shall meet the below specifications using a 500Hz low-pass filter.</p> <p>NORMAL position : -57dB or less METAL/CrO₂ position : -57dB or less</p>	[Mode] PLAY BUTTON ON OUTPUT VOL MAX MON SW TAPE DOLBY SW OFF EQ SW NOR/CrO ₂ or METAL
PB Dolby Check	<p>Play back a blank tape, and check to see that moving the Dolby Sw from OFF to ON position will cause a drop in hiss level.</p>	[Mode] PLAY BUTTON ON OUTPUT VOL MAX MON SW TAPE EQ SW NOR DOLBY SW ON/OFF
Line Level Check	<p>Apply a signal of 100mV (-17.8dB), 400Hz to the line input, and check to see that the line output level falls within 580mV (-2.5dB) ±1.5dB and that channel balance between Lch and Rch falls within 2dB.</p>	[Mode] LINE VOL MAX MIC VOL MIN OUTPUT VOL MAX MON SW SOURCE DOLBY SW OFF
MIC Level Check	<p>Apply a signal of 0.25mV (-70dB), 400Hz to the MIC input, and check to see that the output level falls within 580mV (-2.5dB) ±3dB and that channel balance between Lch and Rch, within 3dB.</p>	[Mode] LINE VOL MIN MIC VOL MAX OUTPUT VOL MAX MON SW SOURCE DOLBY SW OFF
SOURCE MON S/N Check	<p>With the Line Vol at MAX and MIC Vol at MIN, the noise level of SOURCE MON shall fall below -70dB. With the MIC Vol at MAX and the Line Vol at MIN, the noise level of SOURCE MON shall fall below -43dB.</p>	[Mode] OUTPUT VOL MAX MON SW SOURCE LINE VOL MAX/MIN MIC VOL MAX/MIN
Mixing Loss Check	<p>Apply a signal of 100mV (-17.8dB), 400Hz to the line output, turn the Mic Vol from MIN to MAX, and check to see that the change in output level falls within ±1dB. Similarly apply a signal of 0.25mV (-70dB), 400Hz to the MIC input, turn the Input Line Vol from MIN to MAX, and check to see that the change in output level falls within ±1dB.</p>	[Mode] OUTPUT VOL MAX MON SW SOURCE DOLBY SW OFF LINE VOL MAX/MIN MIC VOL MAX/MIN

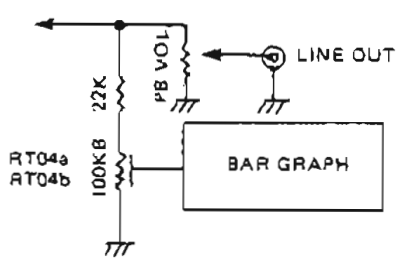
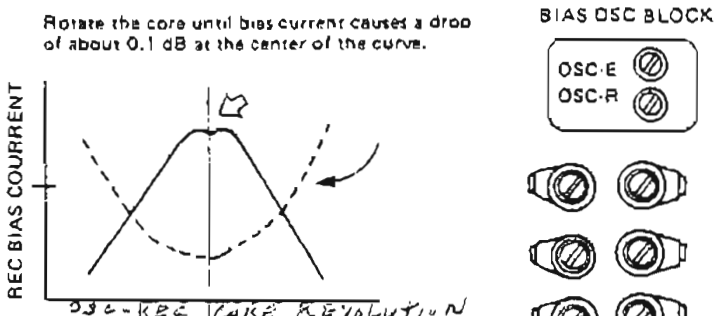
Adjustment and Check Items	Adjusting Procedure	Adjusting Point/Mode
<p>Meter Adjustment (bar graph adjustment)</p>	<p>Apply a signal of approx. 100mV (-17.8dB), 400Hz to the line input, and move the Line Vol until a 580mV (-2.5dB) output develops at the line output. At this point, further microadjust Lch RT04a and Rch RT04b so that the meter will register -1dB when the attenuator reduces the output by 0.6dB. Next restore the line output to 580mV (-2.5dB), operate the attenuator until the output level reaches -3.5dB and -1.5dB, and then check to see that the meter registers -1dB and +1dB respectively.</p> 	<p>{Adjusting Point}</p> <p>Lch RT04a Rch RT04b</p> <p>{Mode}</p> <p>OUTPUT VOL MAX MON SW SOURCE DOLBY SW OFF MIC VOL MIN LINE VOL VARIABLE</p>
<p>Meter Peak Hold Check</p>	<p>Apply a 400Hz signal to the line input, depress the Peak Hold Sw for each of the meter's seven dots ranging from -1dB to +8dB, and check to see that meter pointer is held at each depression of the Peak Hold Sw. In doing this check, use the attenuator to change the input level.</p>	<p>{Mode}</p> <p>LINE VOL MAX OUTPUT VOL MAX MON SW SOURCE</p>
<p>Headphone Output Level Check</p>	<p>Apply a 400Hz signal to the line input, and adjust the Line Vol until the output reaches 580mV (-2.5dB). At this point, connect an 8-ohm load to the headphone output, and check to see that the output level falls within 0.14V (-15dB) ±2.0dB.</p>	<p>{Mode}</p> <p>OUTPUT VOL MAX MON SW SOURCE DOLBY SW OFF</p>
<p>Bias OSC Block Adjustment</p>	<p>Connect a frequency counter to the test points, TP-11(H) and TP-12(E). Set a blank tape, depress the REC/PLAY button, then rotate the OSC block core "OSC-ERASE" until oscillation frequency falls within 105KHz ±0.5KHz. Next, connect the AC voltmeter to Lch TR-5(H), Lch TP-8(E), Rch TP-4(H), and TP-8(E), and adjust the bias OSC block core "OSC-REC" so that bias current reaches a peak.</p> <p>Rotate the core until bias current causes a drop of about 0.1 dB at the center of the curve.</p> 	<p>{Adjusting Point}</p> <p>Lch L03a Rch L03b</p> <p>{Mode}</p> <p>REC/PLAY BUTTON ON (with tape set) BIAS SW METAL DOLBY SW OFF</p>

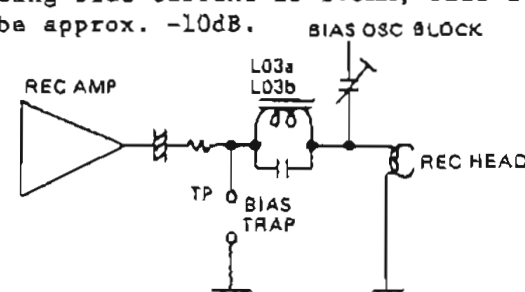
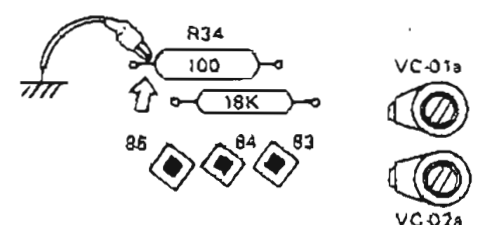
Adjustment and Check Items	Adjusting Procedure	Adjusting Point/Mode								
<p>Adjusting Bias Trap of Recording Amp</p>	<p>Connect an AC voltmeter to the test points, Lch TP9(H), Lch TP-8(E), Rch TP-10(H), and TP-8(E), and adjust the bias trap coils, Lch L03a and Rch L03b to a minimum of bias leakage. If a recording bias current is 1.3mA, bias leakage will be approx. -10dB.</p> 	<p>[Adjusting Point] Lch L03a Rch L03b</p> <p>[Mode] REC/PLAY ON (with tape set) BIAS SW METAL DOLBY SW OFF</p>								
<p>Recording Equalizer Adjustment</p>	<p>Connect an AC voltmeter to the test points, Lch TP-5(H), Lch TP-8(E), Rch TP-4(H), and Rch TP-8(E). Then, to shut off recording bias, ground the resistor R34 with a clip lead.</p>  <p>Next, apply a 10mV (-37.8dB) signal to the line input, and adjust the recording equalizer coils, Lch METAL L04a, Lch NOR L05a, Lch CrO2 L06a, Rch METAL L04b, Rch NOR L05b, and Rch CrO2 L06b so that the peak frequency of the recording equalizer reaches the specified level at each setting of EQ SW (Tape position).</p> <table border="1" data-bbox="462 1500 1165 1702"> <thead> <tr> <th>Tape Selector Sw (EQ. Bias)</th> <th>Recording Equalizer Peak Frequency</th> </tr> </thead> <tbody> <tr> <td>METAL</td> <td>23 KHz</td> </tr> <tr> <td>NORMAL</td> <td>20 KHz</td> </tr> <tr> <td>CrO2</td> <td>20 KHz</td> </tr> </tbody> </table>	Tape Selector Sw (EQ. Bias)	Recording Equalizer Peak Frequency	METAL	23 KHz	NORMAL	20 KHz	CrO2	20 KHz	<p>[Adjusting Point] Lch Rch METAL L04a, L04b NOR L05a, L05b CrO2 L06a, L06b</p> <p>[Mode] REC/PLAY BUTTON ON LINE VOL MAX MIC VOL MIN OUTPUT VOL MAX DOLBY SW OFF BIAS SW · EQ SW NOR/CrO2/METAL</p>
Tape Selector Sw (EQ. Bias)	Recording Equalizer Peak Frequency									
METAL	23 KHz									
NORMAL	20 KHz									
CrO2	20 KHz									

Adjustment and Check Items	Adjusting Procedure	Adjusting Point/Mode																								
<p>Recording Bias Adjustment</p>	<p>Apply a signal of 1KHz -10mV (-37.8dB) to the line input, record the signal at each tape selector position, change bias from High to Low by turning the recording bias control trimmers until an appropriate bias is achieved for each tape selector position.</p> <p>The trimmers are to be set at the positions shown below.</p> <div style="text-align: center;"> </div> <table border="1" style="width: 100%; border-collapse: collapse; margin-top: 20px;"> <thead> <tr> <th style="text-align: left;">Tape Selector (EQ. Bias)</th> <th style="text-align: left;">Tape</th> <th style="text-align: left;">Bias Point</th> </tr> </thead> <tbody> <tr> <td>METAL</td> <td>TDK-AC702</td> <td>Peak</td> </tr> <tr> <td>NORMAL</td> <td>TDK-AC222</td> <td>Peak</td> </tr> <tr> <td>CrO₂</td> <td>TDK-AC512</td> <td>Peak</td> </tr> </tbody> </table> <p>Next, connect an AC voltmeter to the test points, Lch TP-5(H), Lch TP-8(E), Rch TP-4(H), and Rch TP-8(E), and check to see that the following outputs develops with the tape selector switch in respective positions. At this point, no signals are applied to the line and MIC inputs.</p> <table border="1" style="width: 100%; border-collapse: collapse; margin-top: 20px;"> <thead> <tr> <th style="text-align: left;">Tape Selector (EQ. Bias)</th> <th style="text-align: left;">Standard Bias Current</th> <th style="text-align: left;">Range</th> </tr> </thead> <tbody> <tr> <td>NORMAL</td> <td>6.7mV(670uA)</td> <td>5.3mV ~ 8.2mV</td> </tr> <tr> <td>CrO₂</td> <td>8.7mV(870uA)</td> <td>7.0mV ~ 10mV</td> </tr> <tr> <td>METAL</td> <td>13mV(1300uA)</td> <td>11mV ~ 16mV</td> </tr> </tbody> </table> <div style="text-align: center; margin-top: 20px;"> </div>	Tape Selector (EQ. Bias)	Tape	Bias Point	METAL	TDK-AC702	Peak	NORMAL	TDK-AC222	Peak	CrO ₂	TDK-AC512	Peak	Tape Selector (EQ. Bias)	Standard Bias Current	Range	NORMAL	6.7mV(670uA)	5.3mV ~ 8.2mV	CrO ₂	8.7mV(870uA)	7.0mV ~ 10mV	METAL	13mV(1300uA)	11mV ~ 16mV	<p>{Adjusting Point}</p> <p style="text-align: center;">Lch Rch</p> <p>METAL VC01a VC01b</p> <p>NOR VC02a VC02b</p> <p>CrO₂ VC03a VC03b</p> <p>{Mode}</p> <p>REC/PLAY BUTTON ON</p> <p>LINE VOL MAX</p> <p>MIC VOL MIN</p> <p>OUTPUT VOL MAX</p> <p>MON SW TAPE</p> <p>DOLBY SW OFF</p> <p>BIAS FINE CENTER</p> <p>BIAS SW · EQ SW NOR/CrO₂/METAL</p>
Tape Selector (EQ. Bias)	Tape	Bias Point																								
METAL	TDK-AC702	Peak																								
NORMAL	TDK-AC222	Peak																								
CrO ₂	TDK-AC512	Peak																								
Tape Selector (EQ. Bias)	Standard Bias Current	Range																								
NORMAL	6.7mV(670uA)	5.3mV ~ 8.2mV																								
CrO ₂	8.7mV(870uA)	7.0mV ~ 10mV																								
METAL	13mV(1300uA)	11mV ~ 16mV																								

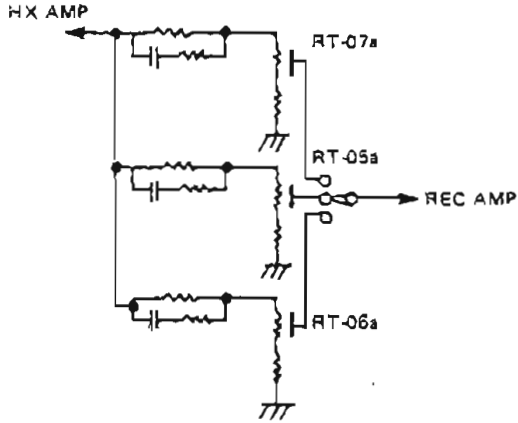
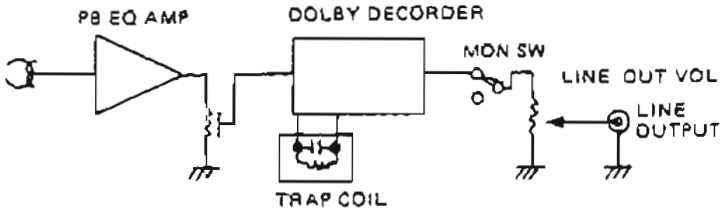
Adjustment and Check Items	Adjusting Procedure	Adjusting Point/Mode																						
Recording Gain Adjustment	<p>Apply a signal of approx. 400Hz 100mV (-17.8dB) to the line input, set the MON Sw at SOURCE, and adjust the Line Vol until the line output reaches 580mV (-2.5dB). Next, depress the REC/PLAY button, and adjust the points, Lch METAL RT07a, Lch NOR RT05a, Lch CrO2 RT06a, Rch METAL RT07b, Rch NOR RT05b, and Rch CrO2 RT06b so that playback output of 580mV (-2.5dB \pm0.5dB) will be obtained.</p>  <p>The above recording gain adjustment should be made again after record/play f-response adjustment has been made.</p>	<p>[Adjusting Point]</p> <table border="0"> <tr> <td></td> <td>Lch</td> <td>Rch</td> </tr> <tr> <td>METAL</td> <td>RT07a</td> <td>RT07b</td> </tr> <tr> <td>NOR</td> <td>RT05a</td> <td>RT05b</td> </tr> <tr> <td>CrO2</td> <td>RT06a</td> <td>RT06b</td> </tr> </table>		Lch	Rch	METAL	RT07a	RT07b	NOR	RT05a	RT05b	CrO2	RT06a	RT06b										
	Lch	Rch																						
METAL	RT07a	RT07b																						
NOR	RT05a	RT05b																						
CrO2	RT06a	RT06b																						
REC MUTE Check	<p>Apply a signal of 400Hz 100mV (-17.8dB) to the line input, depress the REC/PLAY button with an alignment test tape set at NORMAL position, and check to see that a depression of the REC MUTE button will provide a muting effect. At this point, make sure that ON-OFF control of the REC MUTE button will produce no obvious clicks.</p>	<p>[Mode]</p> <table border="0"> <tr> <td>REC/PLAY BUTTON</td> <td>ON</td> </tr> <tr> <td>LINE VOL</td> <td>MAX</td> </tr> <tr> <td>MIC VOL</td> <td>MIN</td> </tr> <tr> <td>OUTPUT VOL</td> <td>MAX</td> </tr> <tr> <td>DOLBY SW</td> <td>OFF</td> </tr> <tr> <td>EQ SW</td> <td>NOR</td> </tr> <tr> <td>BIAS SW</td> <td>NOR</td> </tr> <tr> <td>REC MUTE BUTTON</td> <td>ON/OFF</td> </tr> </table>	REC/PLAY BUTTON	ON	LINE VOL	MAX	MIC VOL	MIN	OUTPUT VOL	MAX	DOLBY SW	OFF	EQ SW	NOR	BIAS SW	NOR	REC MUTE BUTTON	ON/OFF						
REC/PLAY BUTTON	ON																							
LINE VOL	MAX																							
MIC VOL	MIN																							
OUTPUT VOL	MAX																							
DOLBY SW	OFF																							
EQ SW	NOR																							
BIAS SW	NOR																							
REC MUTE BUTTON	ON/OFF																							
PB Bias Trap Adjustment	<p>Depress the REC/PLAY button with a metal tape without applying any signals, and check to see that bias leakage falls below -50dB at the line output. If it exceeds -50dB, adjust the bias trap coils, Lch L01a and Rch L01b.</p> 	<p>[Adjusting Point]</p> <table border="0"> <tr> <td>Lch</td> <td>L01a</td> </tr> <tr> <td>Rch</td> <td>L01b</td> </tr> </table> <p>[Mode]</p> <table border="0"> <tr> <td>REC PLAY BUTTON</td> <td>ON</td> </tr> <tr> <td>OUTPUT VOL</td> <td>MAX</td> </tr> <tr> <td>LINE VOL</td> <td>MAX</td> </tr> <tr> <td>MIC VOL</td> <td>MIN</td> </tr> <tr> <td>MON SW</td> <td>TAPE</td> </tr> <tr> <td>DOLBY SW</td> <td>OFF</td> </tr> <tr> <td>BIAS FINE</td> <td>CENTER</td> </tr> <tr> <td>EQ SW</td> <td>METAL</td> </tr> <tr> <td>BIAS SW</td> <td>METAL</td> </tr> </table>	Lch	L01a	Rch	L01b	REC PLAY BUTTON	ON	OUTPUT VOL	MAX	LINE VOL	MAX	MIC VOL	MIN	MON SW	TAPE	DOLBY SW	OFF	BIAS FINE	CENTER	EQ SW	METAL	BIAS SW	METAL
Lch	L01a																							
Rch	L01b																							
REC PLAY BUTTON	ON																							
OUTPUT VOL	MAX																							
LINE VOL	MAX																							
MIC VOL	MIN																							
MON SW	TAPE																							
DOLBY SW	OFF																							
BIAS FINE	CENTER																							
EQ SW	METAL																							
BIAS SW	METAL																							

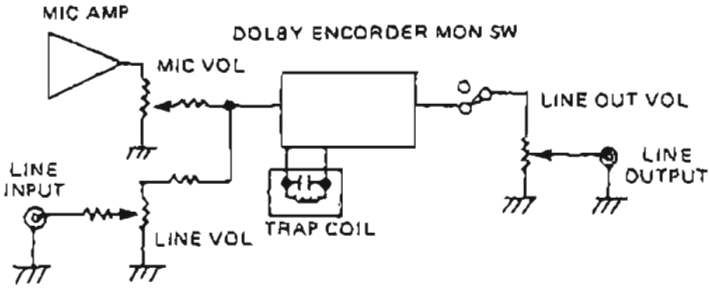
Adjustment and Check Items	Adjusting Procedure	Adjusting Point/Mode
SOURCE MON Bias Trap Adjustment	<p>Depress the REC/PLAY button with a metal tape without applying any signal, and check to see that bias leakage falls within -50dB, adjust the bias trap coils, Lch L02a and Rch L02b.</p> 	<p>[Adjusting Point]</p> <p>Lch L02a Rch L02b</p> <p>[Mode]</p> <p>REC/PLAY BUTTON ON OUTPUT VOL MAX LINE VOL MAX MIC VOL MIN MON SW SOURCE DOLBY SW OFF BIAS FINE CENTER EQ SW METAL BIAS SW METAL</p>
Recording /Playback F-response Adjustment	<p>Apply a signal of 400Hz 7mV (-40.8dB), lower than the meter test level of 160nWb/m by 20dB, to the line input, depress the REC/PLAY button with each of the three types of tapes, and adjust f-response to the specified level for each tape. The reference frequency is 400Hz.</p> <p>{IMPORTANT}</p> <p>In the REC/PLAY monitor mode, a signal propagation from the recording head to the playback head at higher than 10KHz will cause an 1dB increase in f-response. Thus recording then rewinding the tape will eliminate this increase in f-response. In addition, this signal propagation will cause the high-frequency REC/PLAY output to fluctuate.</p> <p>To execute the adjustment, first set the tape selector Sw at the position identical with the type of tape being used, and then record the prescribed level of signal. If the recording equalizer and bias are preset properly, f-response must fall within ±2dB at lower than 10KHz and within approx. ±6dB at approx. 10KHz. In order to accommodate f-response within ±2dB at higher than 10KHz, lock the recording equalizer which controls recording bias. In the event that the f-response becomes the same as shown in the below graph after recording bias is adjusted, the f-response curve shown in the dotted line may be achieved by properly withdrawing the recording equalizer adjusting coil. If the need for raising the recording f-response arises, the method of advancing the recording equalizer coil should be preferably avoided but that of controlling the bias be adopted.</p>	<p>[Adjusting Point]</p> <p><u>REC Bias</u></p> <p>Lch Rch METAL VC01a VC01b NOR VC02a VC01b CrO2 VC03a VC03b</p> <p><u>REC EQ</u></p> <p>Lch Rch Metal L04a L04b NOR L05a L05b CrO2 L06a L06b</p> <p>[Mode]</p> <p>REC/PLAY BUTTON ON LINE VOL MAX MIC VOL MIN OUTPUT VOL MAX MON SW TAPE DOLBY SW OFF BIAS FINE CENTER</p>

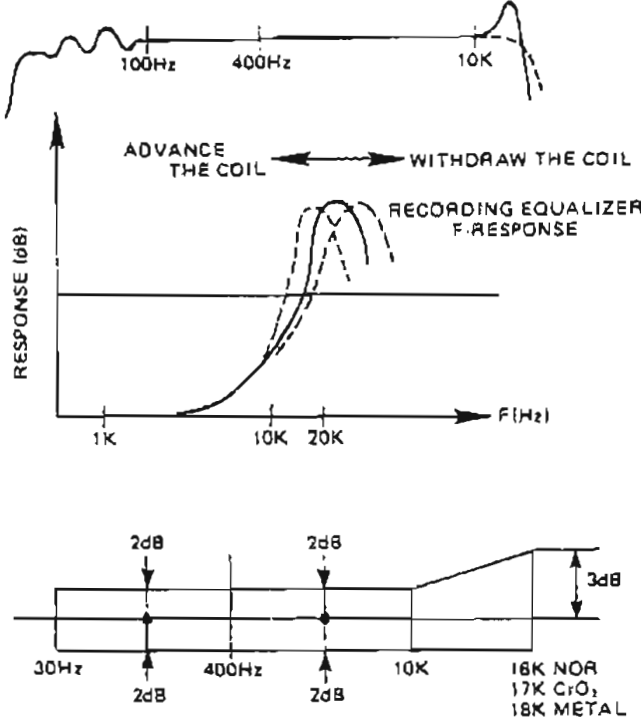
Adjustment and Check Items	Adjusting Procedure	Adjusting Point/Mode
	 <p>The top graph shows the recording equalizer f-response with frequency (F(Hz)) on the x-axis (log scale: 1K, 10K, 20K) and response (dB) on the y-axis. It features a curve that rises from 1KHz and peaks around 20KHz. A horizontal line indicates the reference level. A double-headed arrow labeled 'ADVANCE THE COIL' points left, and another labeled 'WITHDRAW THE COIL' points right. Below the main graph is a smaller graph showing bias fine adjustment characteristics with frequency (Hz) on the x-axis (30Hz, 400Hz, 10K) and response (dB) on the y-axis. It shows a flat line at 2dB with a 2dB adjustment range indicated by arrows. A 3dB adjustment range is also shown at higher frequencies. Labels include '18K NOR', '17K CrO₂', and '18K METAL'.</p> <p>After REC/PLAY f-response is adjusted, the recording gain adjustment shall be made again.</p>	
Distortion Factor Check	Apply a signal of 1KHz, 70mV (-20.8dB) (METER test level 160nWb/m to the line input, and depress the REC/PLAY button with each of the three types of tapes. If distortion factor exceeds 1.4%, increase the bias, and readjust the record/play f-response.	[Mode] REC/PLAY BUTTON ON LINE VOL MAX MIC VOL MIN OUTPUT VOL MAX MON SW TAPE DOLBY SW OFF BIAS FINE MAX/MIN
Bias Fine Vol Check	Apply a signal of 7mV (-40.8 dB) less than 400 Hz, 100mV (-17.8 dB) by 23 dB. Next set a normal alignment tape, depress the REC/PLAY button, then, while rotating the Bias Fine Vol from MIN to MAX, check to see that a change of ± 2 dB or more will occur.	[Mode] REC/PLAY BUTTON ON LINE VOL MAX MIC VOL MIN OUTPUT VOL MAX MON SW TAPE DOLBY SW OFF BIAS FINE MAX/MIN

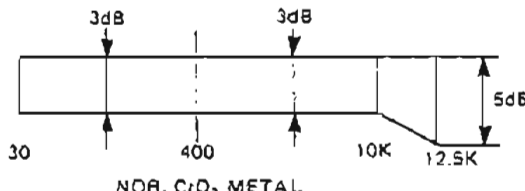
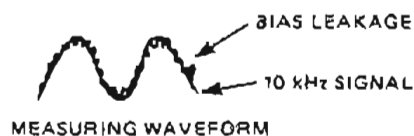
Adjustment and Check Items	Adjusting Procedure	Adjusting Point/Mode												
REC Dolby Record/Play F-response Check	<p>Apply a signal of 5.6mV (-42.8dB) lower than 400Hz, 100mV (-17.8dB) by 25dB. Next, after setting each of the three types of tapes, depress the REC/PLAY button, and check to see that the specified f-response is achieved with each of the tapes. Reference frequency is 400Hz.</p>  <p style="text-align: center;">NOR, CrO₂, METAL</p>	[Mode] REC/PLAY BUTTON LINE VOL ON MIC VOL MAX OUTPUT VOL MIN DOLBY SW MAX BIAS FINE ON MON SW CENTER TAPE												
Dolby Hx Reference Voltage Adjustment	<p>Connect a DC voltmeter across No.8 pin (H) and No.14 pin (E) of Hx PC-B, and adjust RT02, RT01 and RT03 so that setting Tape Selector at NOR, CrO₂ and METAL will develop 5V, 6V and 13V respectively.</p>	[Adjusting Point] Tape Selector (EQ, Bias) NOR RT02 CrO ₂ RT01 METAL RT03												
Dolby Hx Recording Equalizer Check	<p>Apply a signal of approx. 400Hz, 100mV (-17.8dB) to the line input, and set the Line Vol at a point where 580mV (-2.5dB) will develop at the line output with the MON Sw and Dolby Sw both off. Next, connect an AC voltmeter to the test points, Lch TP-9(H), Lch TP-8(E), Rch TP-10(H), and Rch TF-8(E), and increase the signal level from 400Hz to one of the below specified frequencies. Then check to see that the following changes in output level can be obtained by moving the Dolby SW from the ON position to Hx position, depending on the type of tape being set.</p> <table border="1" data-bbox="446 1489 1141 1635"> <thead> <tr> <th>Position</th> <th>F(HZ)</th> <th>Dolby ON → Dolby Hx</th> </tr> </thead> <tbody> <tr> <td>NOR</td> <td>10KHZ</td> <td>approx. 4.5dB down</td> </tr> <tr> <td>CrO₂</td> <td>10KHZ</td> <td>approx. 4.5dB down</td> </tr> <tr> <td>METAL</td> <td>14KHZ</td> <td>approx. 2.5dB down</td> </tr> </tbody> </table>	Position	F(HZ)	Dolby ON → Dolby Hx	NOR	10KHZ	approx. 4.5dB down	CrO ₂	10KHZ	approx. 4.5dB down	METAL	14KHZ	approx. 2.5dB down	[Mode] REC/PLAY BUTTON LINE OUT VOL ON MIC VOL MAX LINE VOL MIN MON SW VARIABLE DOLBY SW SOURCE OFF/ON/HX
Position	F(HZ)	Dolby ON → Dolby Hx												
NOR	10KHZ	approx. 4.5dB down												
CrO ₂	10KHZ	approx. 4.5dB down												
METAL	14KHZ	approx. 2.5dB down												
	<p>The AC voltmeter's output is approx. -4dB for NOR, 0dB for METAL, and -2dB for CrO₂. Remember that if the recording bias tape adjustment is not proper, the bias current and the signal will superimpose, making it impossible to measure.</p>  <p style="text-align: center;">MEASURING WAVEFORM</p>													

Adjustment and Check Items	Adjusting Procedure	Adjusting Point/Mode
Dolby Hx Recording Bias Check	<p>Apply a signal of approx 400Hz, 100mV (-17.8dB), set the MON Sw at SOURCE, and the Dolby Sw at OFF, and adjust the Line Vol so that 580mV (-2.5dB) output develops at the line output. Next, connect an AC voltmeter to the test p points, Lch TP-5(H), Lch TP-8, Rch TP-4(H), and Rch TA-8(E), increase the signal level from 400Hz to 20KHz, and depress the REC/PLAY button with a blank tape. Then, while depressing the REC MUTE button, check to see that moving the Dolby Sw from the ON position to the Hx position will cause the bias current to drop to 60% with the Dolby ON level as 100%.</p>	<p>[Mode] REC/PLAY BUTTON ON OUTPUT VOL MAX LINE VOL VARIABLE MIC VOL MIN BIAS FINE CENTER REC MUTE ON MON SW TAPE/SOURCE DOLBY SW OFF/ON/HX</p>
Dolby Hx Record/Play F-Response Check	<p>Apply a signal of approx. 400 Hz, 100mV (-17.8 dB) to the line input, increase the signal level to 10 kHz, then depress the REC/PLAY button. At this point, by switching the Dolby Sw from ON to Hx position, check to see that the output will change as follows:</p> <p style="text-align: center;">TAPE SELECTOR POSITION DOLBY ON + DOLBY HX</p> <p style="margin-left: 100px;">NOR approx. 4.5 dB up CrO₂ approx. 4.5 dB up METAL No change</p>	<p>[MODE] REC/PLAY BUTTON ON LINE VOL VARIABLE MIC VOL MIN OUTPUT VOL MAX BIAS FINE CENTER MON SW TAPE/SOURCE DOLBY SW OFF/ON/HX</p>
Record Play Noise Level Check	<p>Record with respective tapes without applying any signal, and check to see that the record/play noise and hum levels fall within the specified limits.</p> <p><u>Noise Level</u></p> <p>NORMAL position : -50.5dB or lower METAL/CrO₂ position : -51.5dB or lower</p> <p><u>Hum Level</u></p> <p>A 500Hz low-pass filter is used. NORMAL position : -56dB or lower METAL/CrO₂ position : -56dB or lower</p>	
Erasing Coefficient Check	<p>Apply a signal of 316mV (-7.8dB) higher than 1KHz, 100mV (-17.8dB) by 10dB, and perform recording with a metal tape. Next, after rewinding and erasing it, measure the erasing coefficient through a 1KHz-band-pass filter. The measurement shall be 65dB or higher.</p>	<p>[Mode] REC/PLAY BUTTON ON LINE VOL MAX MIC VOL MIN OUTPUT VOL MAX MON SW TAPE DOLBY SW OFF</p>
Play Action Check	<p>Check to see that the reels do not reverse momentarily at play rise at the start of tape winding. Also check to see that the reels do not reverse momentarily at play fall at the end of tape winding.</p> <p>[Note]</p> <p>It is recommended to mark the test cassette reels as shown in the sketch to ensure easy check for reel reversal.</p>	<p><u>Visual Check</u> STOP → PLAY PLAY → STOP</p>

Adjustment and Check_Items	Adjusting Procedure	Adjusting Point/Mode
REC Action Check	Check to see that the left reel backs off 1/8 to 1/4 revolution at the end of tape winding when the REC STOP button or the PAUSE button is depressed.	<u>Visual Check</u> REC → STOP REC → PAUSE ON
Erasing Failure Check after Switching Back and Forth between REC and PAUSE	Record a 1KHz signal on a tape, and repeat switchover between REC and PAUSE at both the start and end of tape winding without applying any signal. Then play it back and check to see that there is no erasing failure on the tape.	<u>Hearing Test</u> REC MODE TAPE MONITOR PAUSE ON/OFF
REC Mute Timing Check	(1) When in the STOP + REC mode, record a 1KHz signal on the leading portion of the REC mute timing tape, then play it back and check to see there is no hunting at the signal rise. (2) Check to see that depressing the REC MUTE key will immediately effect muting.	<u>Hearing Test</u> STOP + REC TAPE MONITOR REC

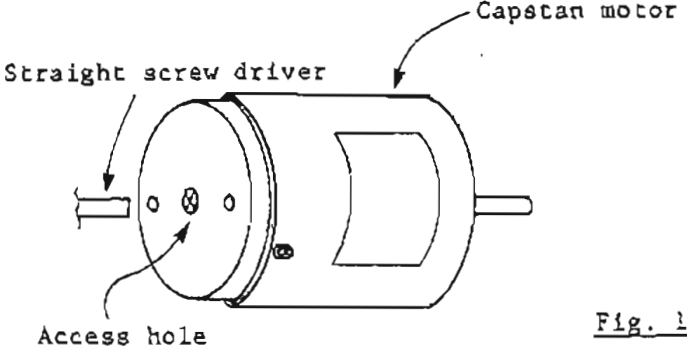
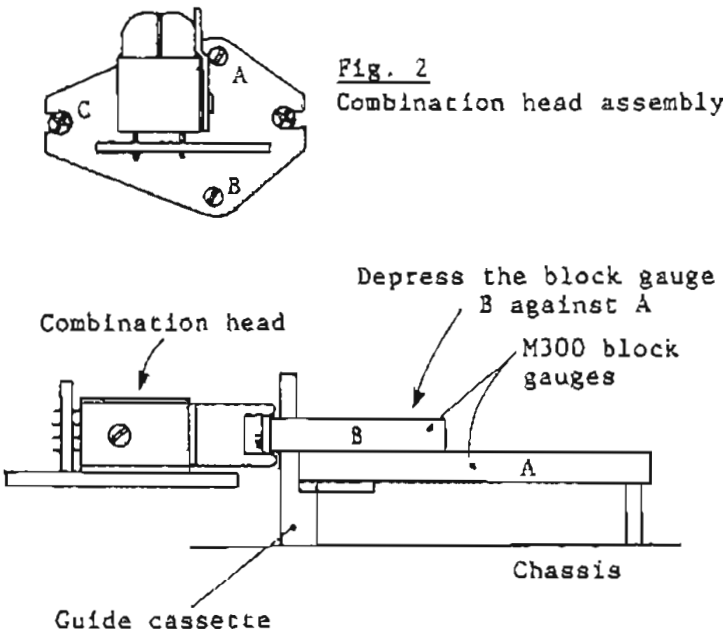
Adjustment and Check Items	Adjusting Procedure	Adjusting Point/Mode
<p>Tape Speed Adjustment</p>	<p>Determine tape speed while playing back a recorded MTT-111 test tape (3KHz). Adjust tape speed by turning the semi-fixed resistor with a small straight screw driver (like a clock screwdriver). To gain access to the semi-fixed resistor, the screwdriver should be inserted into the hole on the back of the capstan motor housing. In doing this adjustment, set the tape position selector at 2,990Hz to start tape winding.</p> <p>[IMPORTANT] The capstan motor stabilizes after one hour of run because it has an approx. 20Hz drift. Thus when tape speed is measured on a machine which has run more than one hour, the semi-fixed resistor must be adjusted for 3,000Hz output.</p>  <p style="text-align: right;">Fig. 1</p>	<p>Adjust the semi-fixed resistor of the capstan motor.</p>
<p>Head Adjustment</p>	<p>Rough-adjust the head with M300 head adjusting block gauges.</p>  <p style="text-align: center;">Fig. 2 Combination head assembly</p> <p style="text-align: center;">Fig. 3 How to use the block gauges</p>	<p>Fig. 2: Screw B for tilt adjustment Screw C for azimuth adjustment Screw A, B, and C for track adjustment</p> <p>Apply the block gauges A and B while depressing the gauge B tightly against the gauge A.</p>

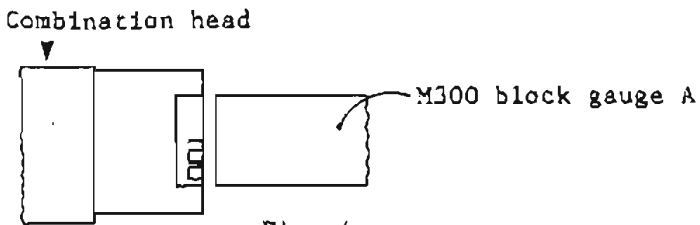
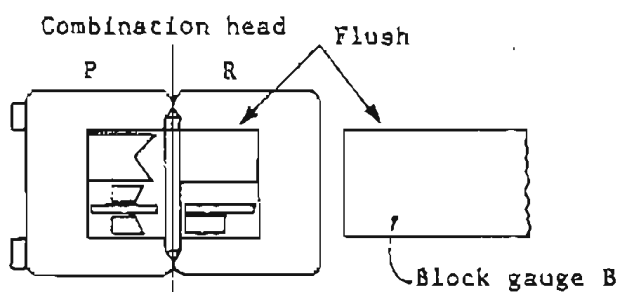
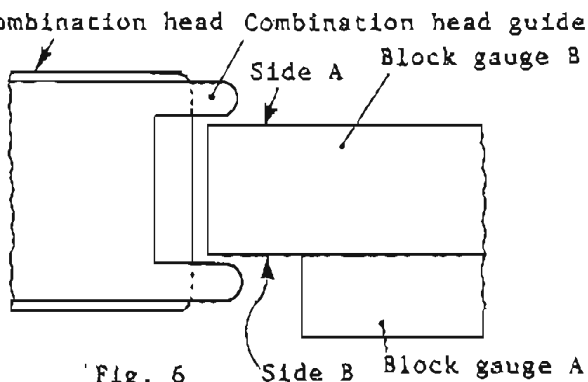
Adjustment and Check Items	Adjusting Procedure	Adjusting Point/Mode
<p>1. Combination Head Rough-Adjustment</p>	<p>A. Tilt adjustment</p>  <p>Fig. 4</p> <p>To do tilt adjustment, set the block gauges A and B as shown in Fig. 3, and turn the screw B until the combination head face goes parallel with the front end of the M300 block gauge A. Check visually for parallelism.</p> <p>B. Azimuth adjustment</p>  <p>Fig. 5</p> <p>To do azimuth adjustment, turn the screw C shown in Fig. 2 until the arrow pointed plane of the combination head goes flush with that of the block gauge B as shown in Fig. 5.</p> <p>C. Track adjustment</p>  <p>Fig. 6</p> <p>The combination head track adjustment should be made in the following manner: Turn the screws A, B and C shown in Fig. 2 the combination head guide is spaced evenly away from both sides A and B of the block gauge B.</p>	<p>Screw B in Fig. 2</p> <p>Screw C in Fig. 2</p> <p>Screws A, B and C in Fig. 2</p>

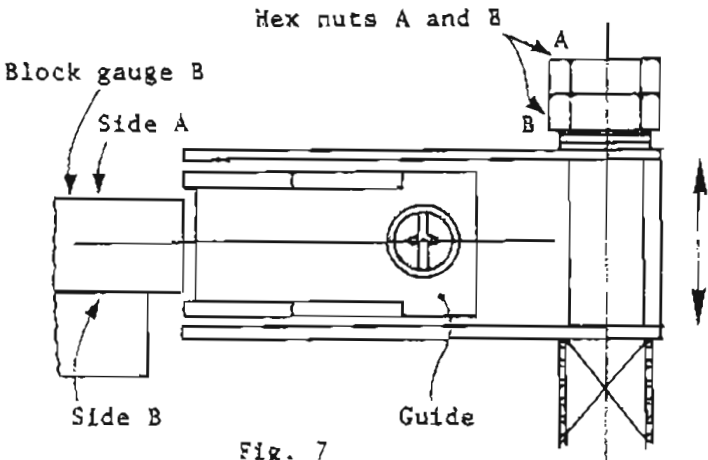
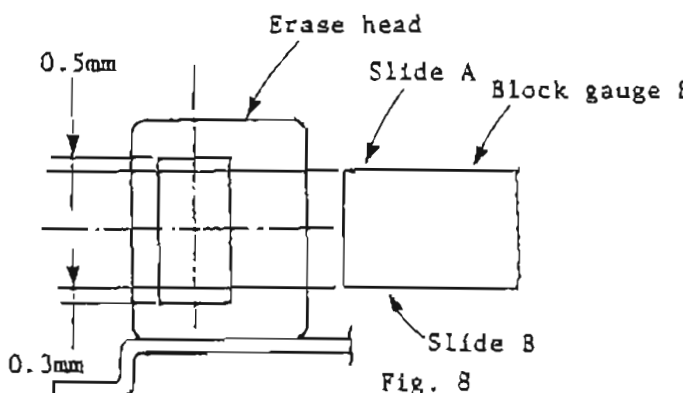
Adjustment and Check Items	Adjusting Procedure	Adjusting Point/Mode
<p>2. Pinch Roller Guide Track Adjustment</p>	<div style="text-align: center;">  <p>Hex nuts A and B</p> <p>Block gauge B</p> <p>Side A</p> <p>Side B</p> <p>Guide</p> <p>Fig. 7</p> </div> <p>To adjust the pinch roller guide track, turn the hex nut A in Fig. 7 until the pinch roller guide is spaced evenly away from both sides of the block gauge B. After adjustment, tighten the hex nut A against B fully and apply a screw lock compound to the hex nuts A and B.</p> <p>[IMPORTANT]</p> <p>To loosen and tighten the hex nuts, use two wrenches at a time, one for clamping the nut B and the other for tightening or loosening the nut A. Otherwise the pinch roller shaft might be subjected to an excessive force, thus causing the pinch roller pressure to be lost.</p>	<p>Hex nuts A and B in Fig. 7</p>
<p>3 Erase Head Track Check and Adjustment</p>	<div style="text-align: center;">  <p>Erase head</p> <p>0.5mm</p> <p>Slide A</p> <p>Block gauge B</p> <p>Slide B</p> <p>0.3mm</p> <p>Fig. 8</p> </div> <p>To check the erase head height, approach the block gauge B to the erase head as shown in Fig. 8 and determine the clearances as shown in Fig. 8. If the clearance between the erase head and the side A of the block gauge B is 0.3 or 0.2mm, place two polyslider washers 0.15mm in thickness and 2mm in diameter one at a point under the erase head mount. Remember that this adjustment is not necessary unless an actual record/play test proves erasing performance to be poor.</p>	<p>Check visually. If adjustment is necessary, use polyslider washers.</p>

Adjustment and Check Items	Adjusting Procedure	Adjusting Point/Mode
<p>4. Tape Travel Check</p>	<div data-bbox="395 405 1134 674" data-label="Image"> </div> <p data-bbox="619 696 903 730" style="text-align: center;">Fig. 9 Skew half</p> <p data-bbox="400 741 496 775">[NOTE]</p> <p data-bbox="400 775 1118 931">A skew half has an opening through which the travelling tape can be seen and contains no guide poles, making it possible to inspect the direct influence of the head, capstan shaft, and pinch roller on the tape.</p> <p data-bbox="400 931 1102 987">Using a skew half, check the following points for tape travelling conditions.</p> <p data-bbox="400 1021 624 1055">[CHECK POINTS]</p> <p data-bbox="400 1066 735 1099">A. Pinch roller guide</p> <p data-bbox="400 1111 1142 1290">Check to see if the tape is forced up and down by the pinch roller guide, thereby being curled by or impinged against it. It does not matter if the tape runs almost on the center of the guide and sometimes gets in slight contact with the guide due to external disturbances.</p> <p data-bbox="400 1323 799 1357">B. Combination head guide</p> <p data-bbox="400 1368 1142 1559">Check to see if the tape is forced up and down by the combination head guide, thereby being curled by or impinged against it. It does not matter if the tape runs almost on the center of the guide and sometimes gets in slight contact with the guide due to external disturbances.</p> <p data-bbox="400 1592 496 1626">[NOTE]</p> <p data-bbox="400 1626 1134 1682">How to adjust the combination head without the availability of M300 block gauges.</p> <p data-bbox="400 1682 1134 1715">Using a skew half, adjust the combination head.</p> <p data-bbox="400 1749 903 1783">A. Pinch roller guide adjustment</p> <p data-bbox="400 1794 1142 1939">Follow the above check point A, and if necessary, align the pinch roller guide to the tape path (instead of the block gauge B) as shown in the Item 2 "Pinch roller guide track adjustment"</p>	<p data-bbox="1190 1794 1437 1850">Hex nuts A and B in Fig. 7</p>

Adjustment and Check Items	Adjusting Procedure	Adjusting Point/Mode
<p>5. Electrical Adjustments of Combination Head</p>	<p>B. Combination head adjustment</p> <p>Follow the check points B in Item 4, and if necessary, execute tilt, azimuth and track adjustments by moving the screws shown in Fig. 2 (refer to "Combination head rough-adjustment" in Item 1) while carefully observing the combination head position relative to tape path. At this point, use a tape in a skew half as an alignment reference as a M300 block gauge is not available.</p> <p>Azimuth adjustment: Play back a recorded test tape TEAD MTT114 (10KHz) and turn the screw C in Fig. 2 until the maximum output level is achieved both in the right and left channels.</p>	<p>Screws A, B and C in Fig. 2</p> <p>Screw C in Fig. 2</p>
<p>Pinch Roller Solenoid Adjustment</p>	<div data-bbox="523 1037 1027 1438" data-label="Image"> </div> <p data-bbox="533 1480 1142 1514"><u>Fig. 10</u> Back view of the mechanism (1)</p> <div data-bbox="475 1592 1230 1989" data-label="Image"> </div> <p data-bbox="730 2011 842 2045"><u>Fig. 11</u></p>	

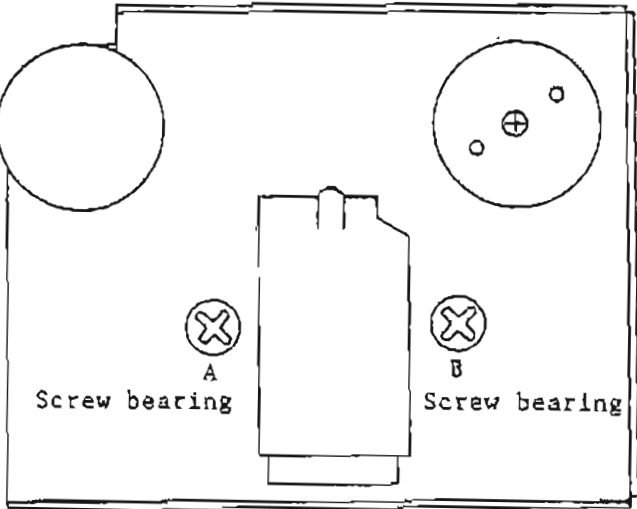
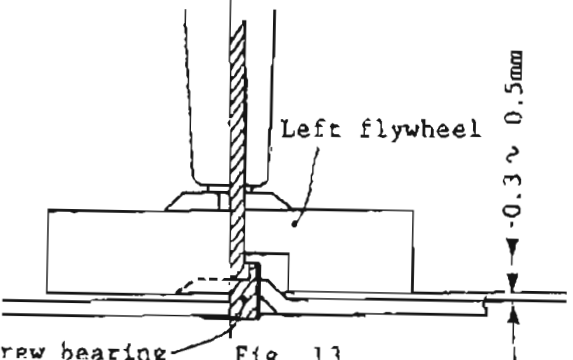
Adjustment and Check Items	Adjusting Procedure	Adjusting Point/Mode
<p>Flywheel Thrust Play Adjustment</p>	<p>Loosen the screws A, B, C and D to allow the pinch roller solenoid assembly to move up and down, and then energize the solenoid. Next, depress the pinch roller solenoid assembly (in the direction of the arrow Fig. 10) to an extent where the base head assembly will come in slight contact with the cushion head base. Finally, tighten the screws A, B, C and D on the pinch roller solenoid assembly.</p> <p>[NOTE] Be sure neither to leave any gap between the base head assembly and the cushion head base nor to force the former excessively against the latter. After tightening the screws A, B, C and D, energize the solenoid and make sure that the base head assembly is in good contact with the cushion head base.</p>  <p>Fig. 12 Rear view of the mechanism (2)</p> <p>A. Right flywheel thrust play adjustment (when seen from the front with the mechanism upright).</p> <p>The right flywheel thrust play should be between 0.1 and 0.3mm. If it falls outside the range, adjust it by turning the screw bearing A in Fig. 12.</p>  <p>Fig. 13</p>	<p>Screws in Fig. 10 "Rear view of the mechanism"</p> <p>Screw bearing A in Fig. 12</p>

Adjustment and Check Items	Adjusting Procedure	Adjusting Point/Mode
	<p>B. Left flywheel screw bearing adjustment (when seen from the front with the mechanism upright)</p> <p>The left flywheel screw bearing should be adjusted as illustrated in Fig. 13 (adjustment range 0.3 to 0.5mm).</p>	<p>Turn the screw bearing B in Fig. 12</p>

BILL OF MATERIAL PCM - 033 VOL PCB Ass'y

SCHEMATIC REF. NUMBER	PART NUMBER	DESCRIPTION	NOTE	QUANTITY PER UNIT
	V - 0010	Volume DM20R748A-10KBX2	16 ϕ -10KBX2	1
	V - 0011	Volume DM20R748A-50KBX2	16 ϕ -50KBX2	1
R01a, b	R - 0016	Carbon Resistor CR25-223J	1/2W 22K	2
R03a, b	R - 0016	Carbon Resistor CR25-183J	1/2W 18K	2
R02a, b	R - 0016	Carbon Resistor CR25-103J	1/2W 10K	2

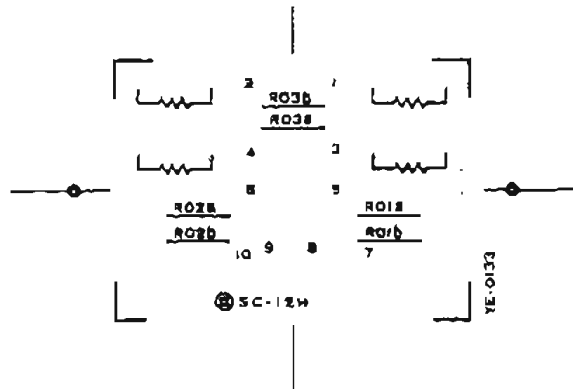

BILL OF MATERIAL PCM - 034 LOGIC PCB Ass'y

SCHEMATIC REF. NUMBER	PART NUMBER	DESCRIPTION	NOTE	QUANTITY PER UNIT
IC1, 4	IC - 0019	IC MM74C00N		2
IC2, 5	IC - 0019	IC MM74C04N		2
IC3	IC - 0018	IC MM74C08N		1
IC6	IC - 0023	IC TC9121P		1
D01 ~ 19	T - 0041	Silicon Diode 1N4448		22
D21 ~ 23	or T - 0053	or 1S1688		
D24	T - 0050	Zener Diode RD7.5EB3		1
D20	T - 0050	" RD3.8EB1		1
Q01 ~ 09	T - 0027	Transistor 2SC1815GR		9
Q10	T - 0028	" 2SA1015GR or Y		1
C01 ~ 12	C - 0015	Ceramic Capacitor DD107F103Z50	0.01 μ /50V	16
C26 ~ 29				
C13	C - 0012	" DD312-950BC104Z26	0.1 μ /25V	1
C14	C - 0003	Electrolytic Capacitor SM16VB-100	100 μ /16V	1
C15	C - 0003	" SM16VB-33	33 μ /16V	1
C16, 18	C - 0024	" CE04W1C100MD	10 μ /16V	6
C23 ~ 25, C30				
C17	C - 0024	" CE04W1H010MD	1 μ /50V	1
C19 ~ 22	C - 0024	" CE04W1E4R7MO	4.7 μ /25V	4
R01 ~ 09	R - 0016	Carbon Resistor CR25-399J	1/2W 39 Ω	10
R61				
R10 ~ 15, 20 ~ 23, 36, 38, 40, 42, 44, 62, 66, 67	R - 0016	" CR25-104J	1/2W 100KJ	18

SCHEMATIC REF. NUMBER	PART NUMBER	DESCRIPTION	NOTE	QUANTITY PER UNIT	
R18, 59	R - 0018	Carbon Resistor	CR25-223J	1/2W 22KJ	2
R17, 18, 71	R - 0018	"	CR25-224J	1/2W 220KJ	3
R19, 26, 28, R31 ~ 35, R37, 39, 41, R43, 46, 48, R51 ~ 55, R63, 70, 75	R - 0018	"	CR25-103J	1/2W 10KJ	22
R24, 48, 59, R60, 64, 85 R72 ~ 74	R - 0016	"	CR25-109J	1/2W 10ΩJ	9
R25	R - 0016	"	CR25-124J	1/2W 120KJ	1
R27, 50	R - 0016	"	CR25-474J	1/2W 470KJ	2
R29, 88	R - 0016	"	CR25-563J	1/2W 56KJ	2
R30	R - 0016	"	CR25-102J	1/2W 1KJ	1
R46	R - 0016	"	CR25-334J	1/2W 330KJ	1
R47	R - 0016	"	CR25-824J	1/2W 820KJ	1
R56, 57	R - 0016	"	CR25-222J	1/2W 2.2KJ	2
R58	R - 0018	"	CR25-105J	1/2W 1MJ	1
R76	R - 0013	"	RD1/2-820J	1/2W 82Ω	1
	B - 0015	Lapping Pin		L = 20 m/m	47

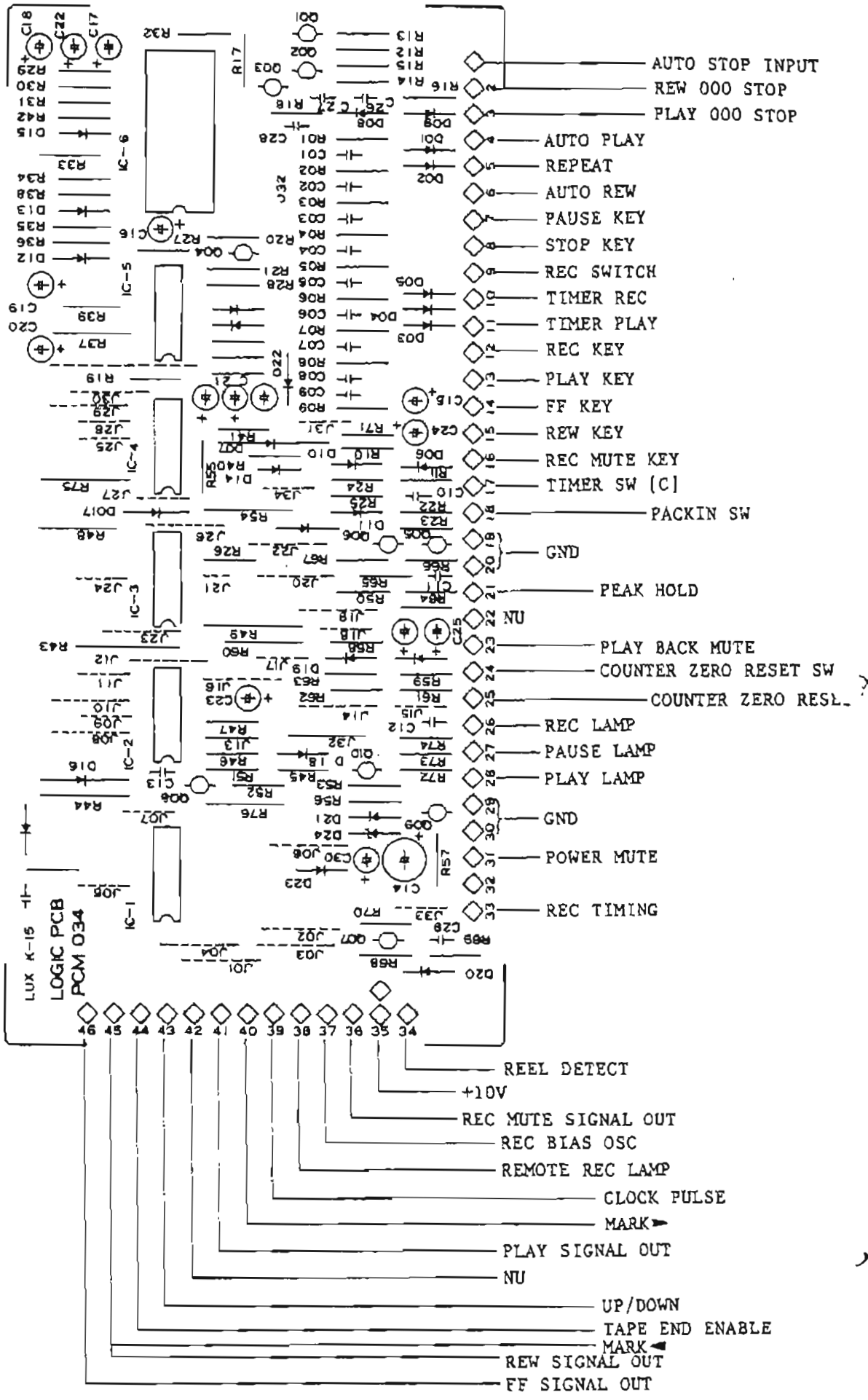

AUTO STOP INPUT
 REW 000 STOP
 PLAY 000 STOP

AUTO PLAY
 REPEAT
 AUTO REW
 PAUSE KEY
 STOP KEY
 REC SWITCH
 TIMER REC
 TIMER PLAY
 REC KEY
 PLAY KEY
 FF KEY
 REW KEY
 REC MUTE KEY
 TIMER SW (C)
 PACKIN SW

GND
 PEAK HOLD
 PLAY BACK MUTE
 COUNTER ZERO RESET SW
 COUNTER ZERO RESL.

REC LAMP
 PAUSE LAMP
 PLAY LAMP
 GND
 POWER MUTE
 REC TIMING

REEL DETECT
 +10V
 REC MUTE SIGNAL OUT
 REC BIAS OSC
 REMOTE REC LAMP
 CLOCK PULSE
 MARK
 PLAY SIGNAL OUT
 NU
 UP/DOWN
 TAPE END ENABLE
 MARK
 REW SIGNAL OUT
 FF SIGNAL OUT

LUX K-15
 LOGIC PCB
 PCM 034

BILL OF MATERIAL PCM - 035 AMP - PCB Ass'y

SCHEMATIC REF. NUMBER	PART NUMBER	DESCRIPTION	NOTE	QUANTITY PER UNIT	
	S - 0023	Slide Switch	SSR28301D	2	
	S - 0024	Slide Switch	SSR22301D	1	
	B - 0015	Lapping Pin	L = 20 m/m	62	
	B - 0001	Terminal Pin	NH-49	10	
(POWER SUPPLY)					
	YM - 0412	Heat Sink - 3006		2	
	M3 x 8	Binding Head Screw		2	
	M3	Hexagon Nut		2	
Q08	T - 0045	Transistor	2SD600 F or E	1	
Q09	T - 0047	Transistor	2SB631 F or E	1	
Q07	T - 0027	Transistor	2SC1815 GR	1	
Q10	T - 0028	Transistor	2SA1015 Yor GR	1	
D03	T - 0005	Silicon Diode Stack	RB-152	1	
ZD01, 02	T - 0050	Zener Diode	RD16EB2	2	
C17, 20	C - 0023	Electrolytic Capacitor	CEUSM1E222	2200/25	2
C16, 19	C - 0023	Electrolytic Capacitor	CEUSM1E102	1000/25	2
C15, 18	C - 0003	Electrolytic Capacitor	SM25VB-220	220/25	2
C14	C - 0003	Electrolytic Capacitor	SM16VB-100	100/16	1
R28, 31	R - 0020	Carbon Resistor	RD¼-22J	¼W 2.2K	2
R29, 30	R - 0020	Carbon Resistor	RD¼-471J	¼W 470Ω	2
R23	R - 0008	Fixed Metal Oxide Film Resistor	RS1BFS-101J	1W 100Ω	1
(MIC AMP)					
IC01	IC - 0022	IC	µPC-4568C	1	
C04, 05	C - 0002	Polyester Film Capacitor	AMS50-473K	0.047/50	2
C37a, b, 38a, b	C - 0005	BP Electrolytic Capacitor	16VB-2R28PD86	BP 2.2/16	4
R24a, b	R - 0020	Carbon Resistor	RD¼-103J	¼W 10K	2
R25a, b	R - 0020	"	RD¼-681J	¼W 680Ω	2
R26a, b, 29a, b	R - 0020	"	RD¼-104J	¼W 100K	4
R27a, b	R - 0020	"	RD¼-274J	¼W 270K	2
R28a, b	R - 0020	"	RD¼-221J	¼W 220Ω	2
R30a, b	R - 0020	"	RD¼-122J	¼W 1.2K	2
(DOLBY ENCODER), (REC. DOLBY)					
L02a, b	L - 0013	Bias Trap Coil	42-1168-02	2	
IC02a, b	IC - 0020	Dolby NR IC	NE645B	2	
D03a, b	T - 0041	Silicon Diode	1N4448 or 1S1588	2	
C17a, b	C - 0002	Polyester Film Capacitor	AMS50-102K	0.001/50V	2
C20a, b	C - 0002	"	AMS50-472J	0.0047/50V	2
C21a, b	C - 0002	"	AMS50-562J	0.0056/50V	2
C23a, b	C - 0002	"	AMS50-273J	0.027/50V	2
C26a, b	C - 0002	"	AMS50-473J	0.047/50V	2
C24a, b	C - 0002	"	AMS50-104J	0.1/50V	2
C25a, b	C - 0002	"	AMS50-334J	0.33/50V	2
C10, 11	C - 0003	Electrolytic Capacitor	SM16VB-220	220/16V	2
C22a, b	C - 0003	"	SM16VB-10	10/16V	2
C18a, b	C - 0005	BP Electrolytic Capacitor	50VB-18PD86	BP 1/50V	2

SCHEMATIC REF. NUMBER	PART NUMBER	DESCRIPTION	NOTE	QUANTITY PER UNIT
C18a,b 19a,b 27a,b	C - 0005	BP Electrolytic Capacitor 16VB-108PD86	BP 10/16V	6
R8, 9	R - 0008	Fixed Metal Oxide Film Resistor RS28FS-181J	2W 180Ω	2
R31a, b	R - 0020	Carbon Resistor RD½-181J	¼W 180Ω	2
R32a, b	R - 0020	" RD½-332J	¼W 3.3K	2
R33a, b	R - 0020	" RD½-473J	¼W 47K	2
R34a, b	R - 0020	" RD½-274J	¼W 270K	2
R35a, b	R - 0020	" RD½-184J	¼W 180K	2
R36a, b	R - 0020	" RD½-103J	¼W 10K	2
(REC EQ AMP)				
L30a, b	L - 0012	Bias Trap Coil 25-2256-13	7 mH	2
L04a, b	L - 0014	Peaking Coil 3-2797-01	3.6 mH	2
L08a, b	L - 0017	" 3-2806-01	7.6 mH	2
L05a, b	L - 0016	" 3-2798-01	8.8 mH	2
RT05a,b ~ 07a,b	R - 0009	Semi-Fixed, volume SR19R-22KΩB	22 KB	6
IC02	IC - 0022	IC μPC4556C		1
Q05	T - 0028	Transistor 2SA1015 Y or GR		1
Q06, Q06a,b	T - 0027	" 2SC1815GR		3
D04a, b	T - 0041	Silicon Diode 1N4448 or 1S1588		2
C32a, b	C - 0002	Polyester Film Capacitor AMS50-104K	0.1/50V	2
C23, 24	C - 0002	" AMS50-473K	0.047/50V	2
C34a, b	C - 0002	" AMS50-123J	0.012/50V	2
C36a, b	C - 0002	" AMS50-103J	0.01/50V	2
C35a, b	C - 0002	" AMS50-822J	0.0082/50V	2
C29a, b	C - 0022	Polystyrene Film-capacitor CQ09S-1H-821-J05B	820P/50V	2
C33a, b	C - 0022	" CQ09S-1H-301-J05B	300P/50V	2
C40a, b	C - 0022	" CQ09S-1H-221-J06B	220P/50V	2
C30a, b	C - 0022	" CQ09S-1H-681-J06B	680P/50V	2
C39a, b	C - 0007	FMCON FM06ZC150J5	15P/60V	2
C13, C31a, b	C - 0005	BP Electrolytic Capacitor 16VB-108PD6	10/16V	2
C28a, b	C - 0005	" 16VB-2R28PD6	2.2/16V	3
R15, 17, 18	R - 0020	Carbon Resistor RD½-104J	¼W 100K	3
R18	R - 0020	" RD½-473J	¼W 47K	1
R20	R - 0020	" RD½-152J	¼W 1.5K	1
R37a,b, 39a,b,	R - 0020	" RD½-683J	¼W 68K	6
R40a,b				
R38a,b, 41a,b	R - 0020	" RD½-124J	¼W 120K	4
R42a,b, 43a,b,	R - 0020	" RD½-103J	¼W 10K	9
R44a,b, 55a,b	R - 0020			
R19				
R45a, b	R - 0020	" RD½-224J	¼W 220K	2
R47a, b	R - 0020	" RD½-273J	¼W 27K	2
R48a, b	R - 0020	" RD½-183J	¼W 18K	2
R49a, b	R - 0020	" RD½-121J	¼W 120Ω	2
R50a, b	R - 0020	" RD½-221J	¼W 220Ω	2
R51a, b	R - 0020	" RD½-181J	¼W 180Ω	2
R46a,b, 52a,b	R - 0020	" RD½-392J	¼W 3.9K	4

SCHEMATIC REF. NUMBER	PART NUMBER	DESCRIPTION	NOTE	QUANTITY PER UNIT	
	BIAS OSC				
	Z - 0036	Bias Osc Blok		1	
Q11, 12	Y - 0052	Transistor	ZSD883 E or F	2	
Q13	T - 0027	"	ZSC1815 GR	1	
VC01a,b ~ 03a,b	C - 0025	Ceramic Trimmer-capacitor		6	
		ECV-1ZW60x32E			
C21	C - 0003	Electrolytic Capacitor	SM25V8-47	47/25V	1
C22	C - 0003	"	SM25V8-10	10/25V	1
R21	R - 0020	Carbon Resistor	RD $\frac{1}{4}$ -010J	$\frac{1}{4}$ W 1 Ω	1
R22, 34	R - 0020	"	RD $\frac{1}{4}$ -101J	$\frac{1}{4}$ W 100 Ω	2
R24	R - 0020	"	RD $\frac{1}{4}$ -273J	$\frac{1}{4}$ W 27K	1
R25	R - 0020	"	RD $\frac{1}{4}$ -182J	$\frac{1}{4}$ W 1.8K	1
R26	R - 0020	"	RD $\frac{1}{4}$ -104J	$\frac{1}{4}$ W 100K	1
R27	R - 0020	"	RD $\frac{1}{4}$ -103J	$\frac{1}{4}$ W 10K	1
R32	R - 0020	"	RD $\frac{1}{4}$ -183J	$\frac{1}{4}$ W 18K	1
R33	R - 0022	Film Proof Coat-Resistor	ROF50S22 Ω J	$\frac{1}{2}$ W 22 Ω	1
R53a, b	R - 0020	Carbon Resistor	RD $\frac{1}{4}$ -100J	$\frac{1}{4}$ W 10 Ω	2
	(P/B EQ AMP)				
RT01a, b	R - 0010	Semi-fixed volume	CR19R-470 Ω B		2
RT02a, b	R - 0009	"	S19R-10K Ω B		2
RT03a, b	R - 0009	"	SR19R-22K Ω B		2
-	YM - 0306	Transistor, Cap	3046		2
Q01a,b, 02a,b	T - 0040	FET	ZSK68AL1		4
Q03a, b	T - 0049	Transistor	ZSA798G		2
Q04a, b	T - 0048	Transistor	ZSC1222E		2
Q05a, b	T - 0026	FET	ZSK30AGR2TM		2
D01a, b	T - 0041	Silicon Diode	1N4448 or 1S1588		2
C01a, b	C - 0022	Polystyrene Film-capacitor		330P/50V	2
			CQ09S-1H-331-J05B		
C04a, b	C - 0022	"	CQ09S-1H-562-J05B	5600P/50V	2
C2, 3	C - 0002	Polyester, Film Capacitor		0.047/50V	2
			AMS60-473K		
C01	C - 0005	8P Electrolytic Capacitor	50VB-18PDB6	8P 1/50V	1
C05a, b	C - 0005	"	16VB-2R2BPD86	8P 2.2/16V	2
C02a,b, 03a,b	C - 0007	FMCON	FM05ZC150J5	15P/50V	4
R01	R - 0020	Carbon Resistor	RD $\frac{1}{4}$ -473J	$\frac{1}{4}$ W 47K	1
R01a, b	R - 0020	"	RD $\frac{1}{4}$ -394J	$\frac{1}{4}$ W 390K	2
R02	R - 0020	"	RD $\frac{1}{4}$ -474J	$\frac{1}{4}$ W 470K	1
R02a,b, 03a,b	R - 0020	"	RD $\frac{1}{4}$ -682J	$\frac{1}{4}$ W 6.8K	4
R04a,b, 05a,b	R - 0020	"	RD $\frac{1}{4}$ -221J	$\frac{1}{4}$ W 220 Ω	6
R15a, b					
R06a,b 16a,b	R - 0020	"	RD $\frac{1}{4}$ -223J	$\frac{1}{4}$ W 22K	4
R07a, b	R - 0020	"	RD $\frac{1}{4}$ -471J	$\frac{1}{4}$ W 470 Ω	2
R08a, b	R - 0020	"	RD $\frac{1}{4}$ -152J	$\frac{1}{4}$ W 1.5K	2
R09a,b 10a,b	R - 0020	"	RD $\frac{1}{4}$ -273J	$\frac{1}{4}$ W 27K	4
R11a, b	R - 0020	"	RD $\frac{1}{4}$ -472J	$\frac{1}{4}$ W 4.7K	2
R12a, b	R - 0020	"	RD $\frac{1}{4}$ -684J	$\frac{1}{4}$ W 680K	2
R13a, b	R - 0020	"	RD $\frac{1}{4}$ -153J	$\frac{1}{4}$ W 15K	2
R14a, b	R - 0020	"	RD $\frac{1}{4}$ -123J	$\frac{1}{4}$ W 12K	2

SCHEMATIC REF. NUMBER	PART NUMBER	DESCRIPTION	NOTE	QUANTITY PER UNIT
(DOLBY DECODER), (P/B DOLBY)				
L01a, b	L - 0013	Bias Trap Coil 42-1168-02		2
IC01a, b	IC - 0020	Dolby NR IC NE6458		2
D02a, b	T - 0041	Silicon Diode 1N4448 or 1S1588		2
Q01	T - 0027	Transistor 2SC1815GR		1
C08a, b	C - 0002	Polyester Film Capacitor AMS50-102K	0.001/50V	2
C10a, b	C - 0002	" AMS50-472J	0.0047/50V	2
C09a, b	C - 0002	" AMS50-562J	0.0056/50V	2
C11a, b	C - 0002	" AMS50-273J	0.027/50V	2
C14a, b	C - 0002	" AMS50-473J	0.047/50V	2
C12a, b	C - 0002	" AMS50-104J	0.1/50V	2
C13a, b	C - 0002	" AMS50-334J	0.33/50V	2
C08, 09	C - 0003	Electrolytic Capacitor SM16VB-220	220/16V	2
C07	C - 0003	" SM16VB-47	47/16V	1
C06	C - 0003	" SM16VB-10	10/16V	3
C06a, b	C - 0005	BP Electroly Capacitor 50VB-1BPDB6	BP 1/50V	2
C07a, b, R41a, b	C - 0005	" 18VB-10BPDB6	BP 10/16V	4
R03	R - 0020	Carbon Resistor RD $\frac{1}{4}$ -154J	$\frac{1}{4}$ W 150K	1
R05	R - 0020	" RD $\frac{1}{4}$ -104J	$\frac{1}{4}$ W 100K	1
R04, R17a, b	R - 0020	" RD $\frac{1}{4}$ -103J	$\frac{1}{4}$ W 10K	3
R06, 07	R - 0008	Fixed Metal Oxide-Film Resistor RS2BFS-181J	2W 180 Ω	2
R18a, b	R - 0020	Carbon Resistor RD $\frac{1}{4}$ -181J	$\frac{1}{4}$ W 180 Ω	2
R19a, b	R - 0020	" RD $\frac{1}{4}$ -332J	$\frac{1}{4}$ W 3.3K	2
R20a, b	R - 0020	Carbon Resistor RD $\frac{1}{4}$ -473J	$\frac{1}{4}$ W 47K	2
R21a, b	R - 0020	" RD $\frac{1}{4}$ -274J	$\frac{1}{4}$ W 270K	2
R22a, b	R - 0020	" RD $\frac{1}{4}$ -184J	$\frac{1}{4}$ W 180K	2
R23a, b	R - 0020	" RD $\frac{1}{4}$ -101J	$\frac{1}{4}$ W 100 Ω	2
(MUTING)				
RY01	L - 0001	Relay BR221D012		1
D01, 02	T - 0041	Silicon Diode 1N4448 or 1S1588		2
Q03, 04	T - 0027	Transistor 2SC1815GR		2
Q02	T - 0028	" ZSA1015 YorGR		1
C12	C - 0003	Electrolytic, Capacitor SM25VB-R47	0.47/25V	1
R10	R - 0020	Carbon Resistor RD $\frac{1}{4}$ -100J	$\frac{1}{4}$ W 10 Ω	1
R11	R - 0020	" RD $\frac{1}{4}$ -105J	$\frac{1}{4}$ W 1M Ω	1
R13, 14	R - 0020	" RD $\frac{1}{4}$ -103J	$\frac{1}{4}$ W 10K	2
R12	R - 0008	Fixed Metal Oxide - Film Resistor RS1BFS-151J	1W 150 Ω	1
(METER)				
RT04a, b	R - 0009	Semi-fixed volume SR19R-100KB		2
R54a, b	T - 0020	Carbon Resistor RD $\frac{1}{4}$ -223J	$\frac{1}{4}$ W 22K	2

BILL OF MATERIAL PCM - 036 LOGIC P.S. PCB Ass'y

SCHEMATIC REF. NUMBER	PART NUMBER	DESCRIPTION	NOTE	QUANTITY PER UNIT
	YM - 0412	Heat Sink-3006		2
	M3x12	Binding Head Screw		2
	M3	Hexagon Nut		5
	3x6x0.5	Washer		3
	φ3	Spring Washer		3
	YM - 0434	Heat Sink-3007		1
	M3x4	Binding Head Screw		1
	M3x10	Binding Head Screw		1
Q02, 06, 08	T - 0044	Transistor	2SD313E or F	3
Q04, 16, 18	T - 0045	"	2S0600E or F	3
Q09, 12	T - 0052	"	2S0863E or F	2
Q10, 11	T - 0051	"	2S8764E or F	2
Q01, 03, 05, Q07, 13, 14 Q15, 17	T - 0027	"	2SC1815GR	8
Q01, 02	T - 0005	Silicon Diode Stack	RB-152	2
D03	T - 0016	Silicon Diode	GP-15D	1
D04	T - 0015	"	1N4003	1
D07 ~ 16	T - 0041	"	1N4448	10
	or T - 0053		or 1S1588	
D05	T - 0050	Zener Diode	RD20EB3	1
D06	T - 0050	"	RD11EB3	1
R03	R - 0013	Carbon Resistor	RD½-102J	1
R04, 05	R - 0020	Flame Proof Coat-Resistor	RDF25S10ΩJ	2
C01, 09	C - 0023	Electrolytic Capacitor	CEUSM1V102	2
C02, 03	C - 0003	Electrolytic Capacitor	SM25VB-100	2
C04, 05, 10 C08	C - 0023	"	CEUSM1E102	4
C06, 07	C - 0003	"	SM16VB-100	2
C09	C - 0003	"	SM6.3VB-100	1
C12, 14	C - 0003	"	SM16VB-10	2
C13	C - 0003	"	SM25VB-10	1
C16	C - 0003	"	SM50VB-4R7	1
C15	C - 0024	"	CE04W1HR47MD	1
R01, 10 ~ 13 R17, 28	R - 0016	Carbon Resistor	CR25-103J	7
R02, 14	R - 0016	"	CR25-392J	2
R06, 07	R - 0016	"	CR25-159J	2
R09	R - 0016	"	CR25-822J	1
R15	R - 0016	"	CR25-221J	1
R16, 21	R - 0016	"	CR25-104J	2
R18, 19	R - 0016	"	CR25-223J	2
R20	R - 0016	"	CR25-333J	1
R22, 23, 24, R25, 26, 27	R - 0016	"	CR25-222J	8
R29	R - 0016	"	CR25-124J	1

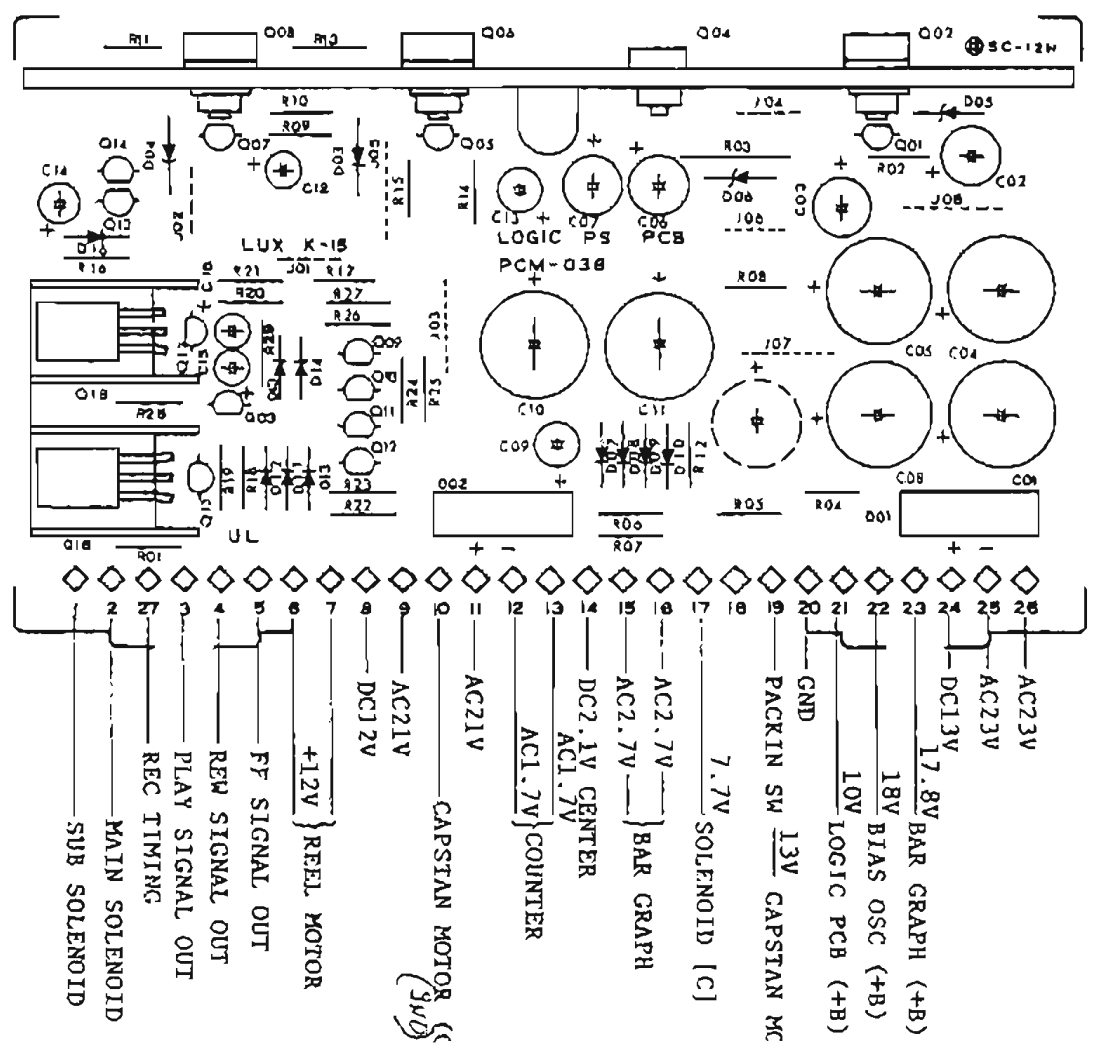
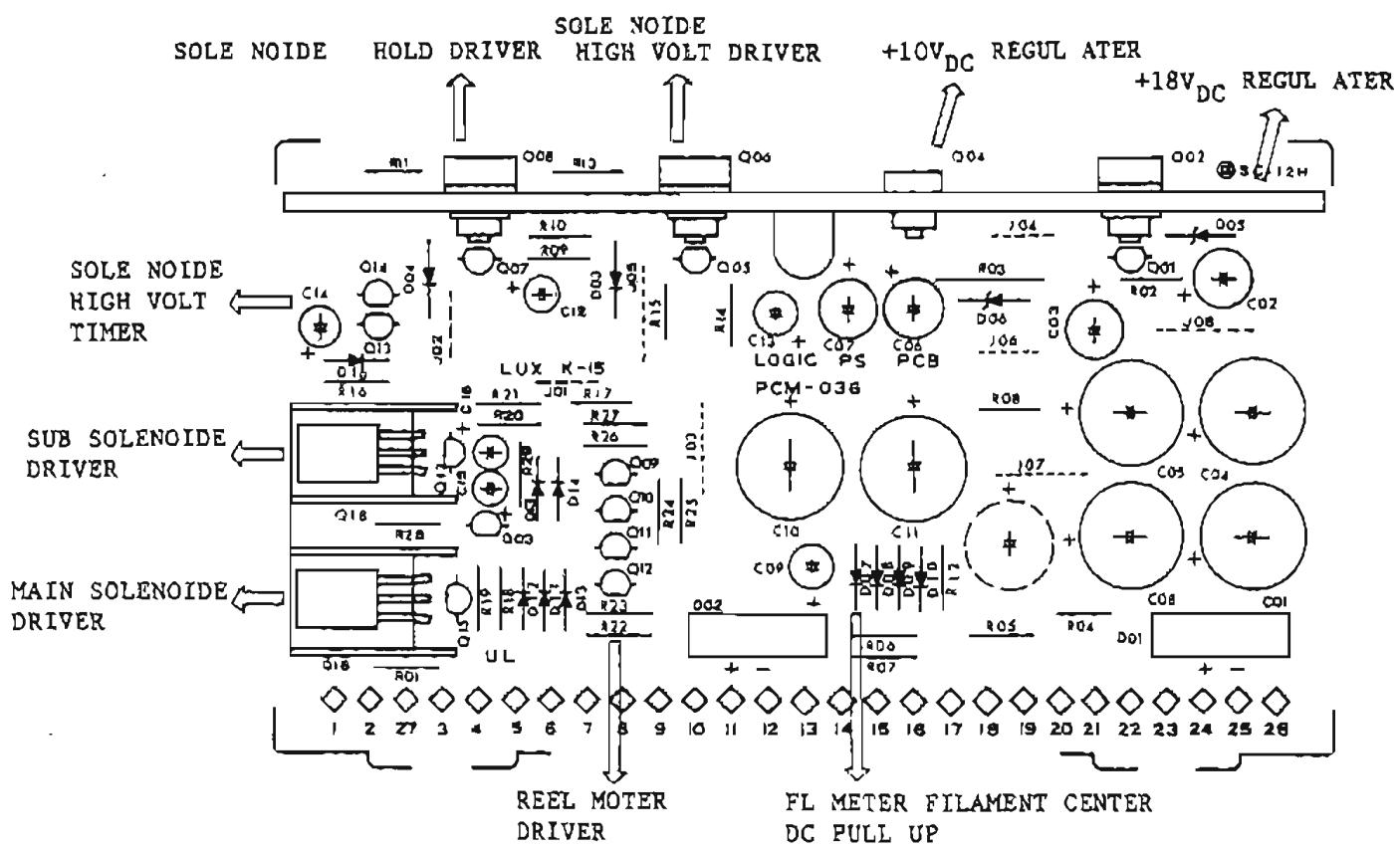

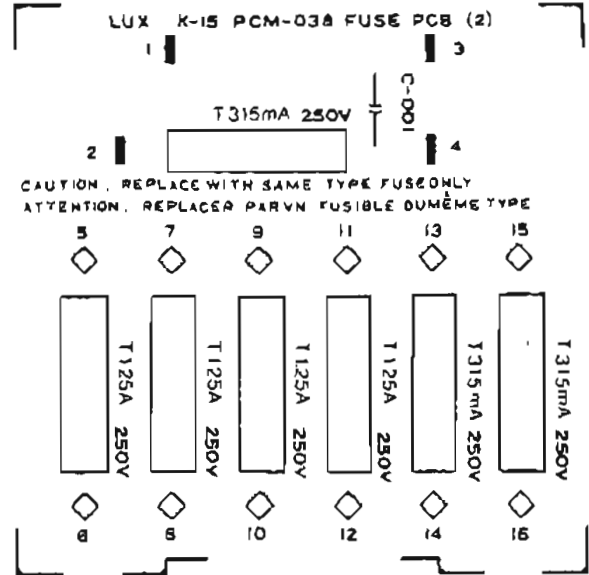
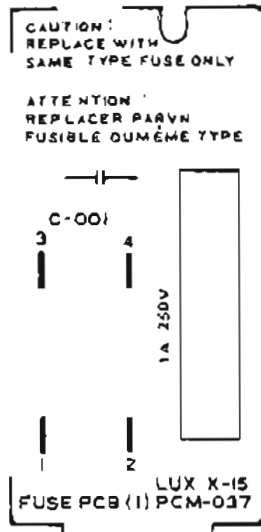

BILL OF MATERIAL PCM-039 Dolby HX PCB Ass'y

SCHEMATIC REF. NUMBER	PART NUMBER	DESCRIPTION	NOTE	QUANTITY PER UNIT
IC1	IC - 0025	IC LM324N.		1
IC2	IC - 0024	IC LM13600N		1
IC3	IC - 0022	IC μ PC4556C		1
Q01	T - 0027	Transistor 2SC1815GR		1
D01 ~ 03	T - 0041 or T - 0053	Silicon Diode 1N4448 or 1S1588		3
C01	C - 0022	Polystyrene Film Capacitor	360P/50V	1
		CQ09S-1H-361-J05B		
C02a, b	C - 0022	"	150P/50V	2
C03a, b	C - 0022	"	1500P/50V	2
C01a, b	C - 0023	Electrolytic Capacitor	CEUSM1H2R2	2.2 μ /50
C02, 04, 05a, b	C - 0023	"	CEUSM1C100	10 μ /16
C04a, b	C - 0023	"	CEUSM1C470	47 μ /16
R01, 01a, b	R - 0016	Carbon Resistor	CR25-104J	$\frac{1}{2}$ W 100KJ
R07, 08				
R02, 08a, b	R - 0016	"	CR25-473J	$\frac{1}{2}$ W 47KJ
R03	R - 0018	"	CR25-224J	$\frac{1}{2}$ W 220KJ
R03a, b, 05a, b	R - 0016	"	CR25-221J	$\frac{1}{2}$ W 220 Ω J
R04	R - 0016	"	CR25-564J	$\frac{1}{2}$ W 560KJ
R04a, b	R - 0016	"	CR25-222J	$\frac{1}{2}$ W 2.2KJ
R05	R - 0016	"	CR25-154J	$\frac{1}{2}$ W 150KJ
R08a, b, 10	R - 0018	"	CR25-102J	$\frac{1}{2}$ W 1KJ
R09	R - 0018	"	CR25-122J	$\frac{1}{2}$ W 1.2KJ
R11	R - 0016	"	CR25-392J	$\frac{1}{2}$ W 3.9KJ
R14	R - 0016	"	CR25-153J	$\frac{1}{2}$ W 15KJ
R02a, b, 08,	R - 0016	Carbon Resistor	CR25-103J	$\frac{1}{2}$ W 10KJ
R07a, b, 12,				
R13, 15, 16				
RT01, 02, 03	R - 009	Semi-fixed volume	SR19R-10KB	3

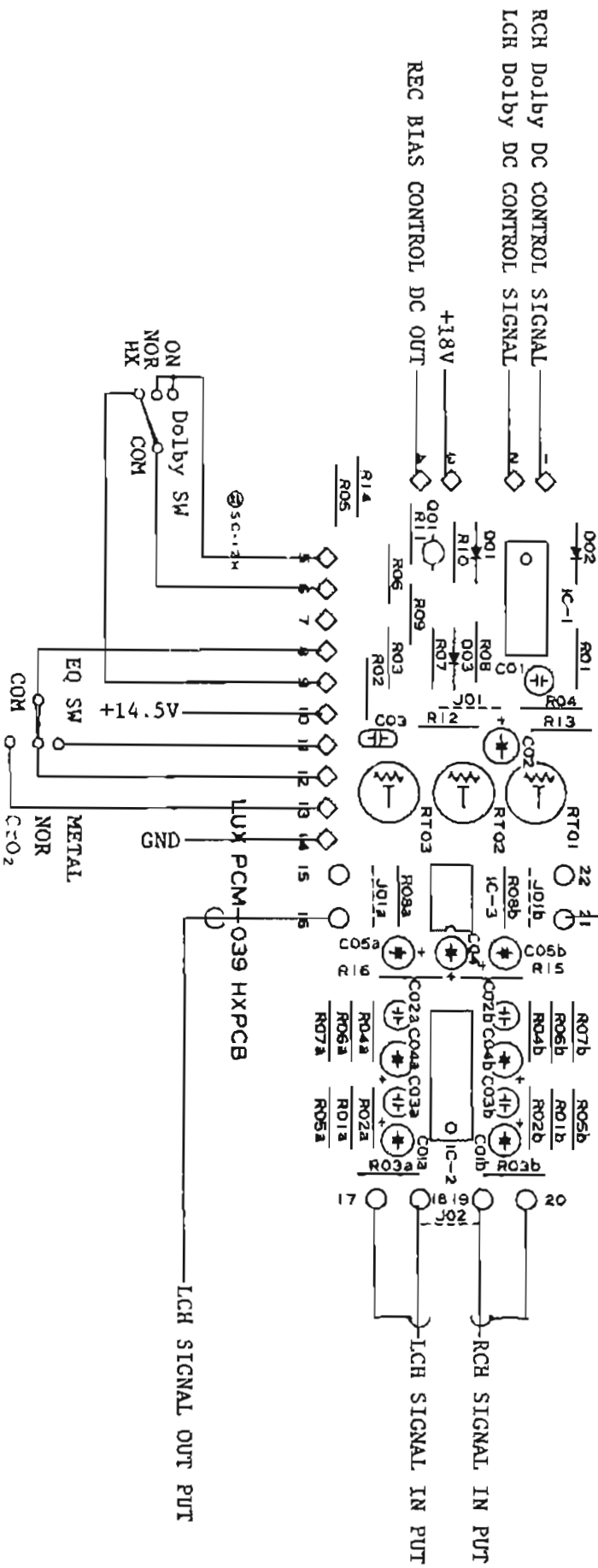
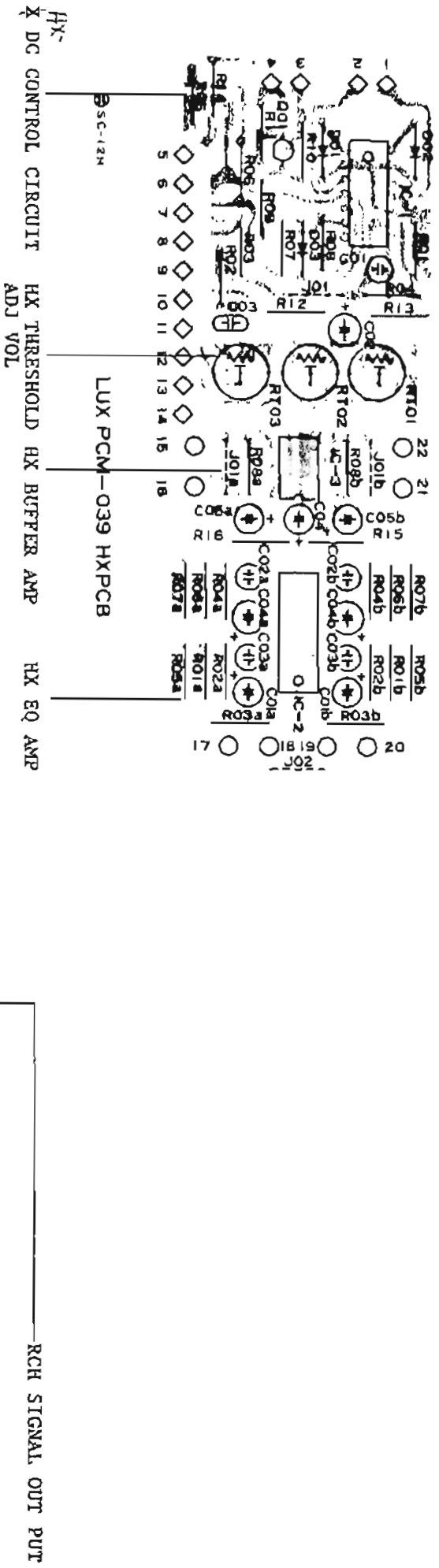

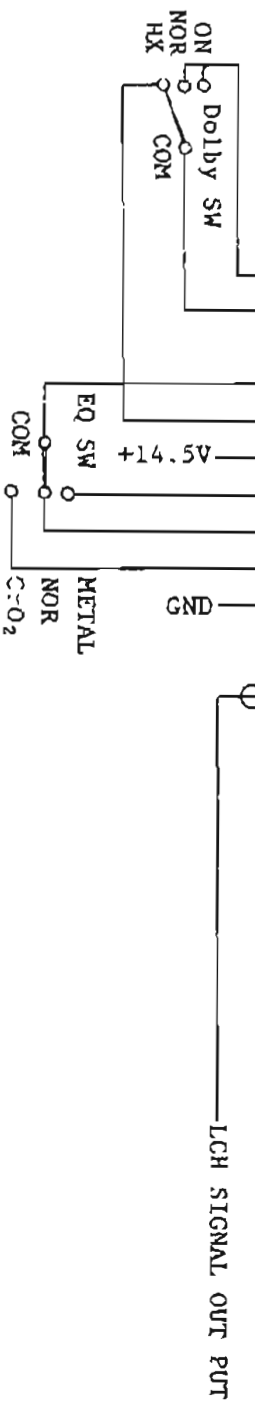
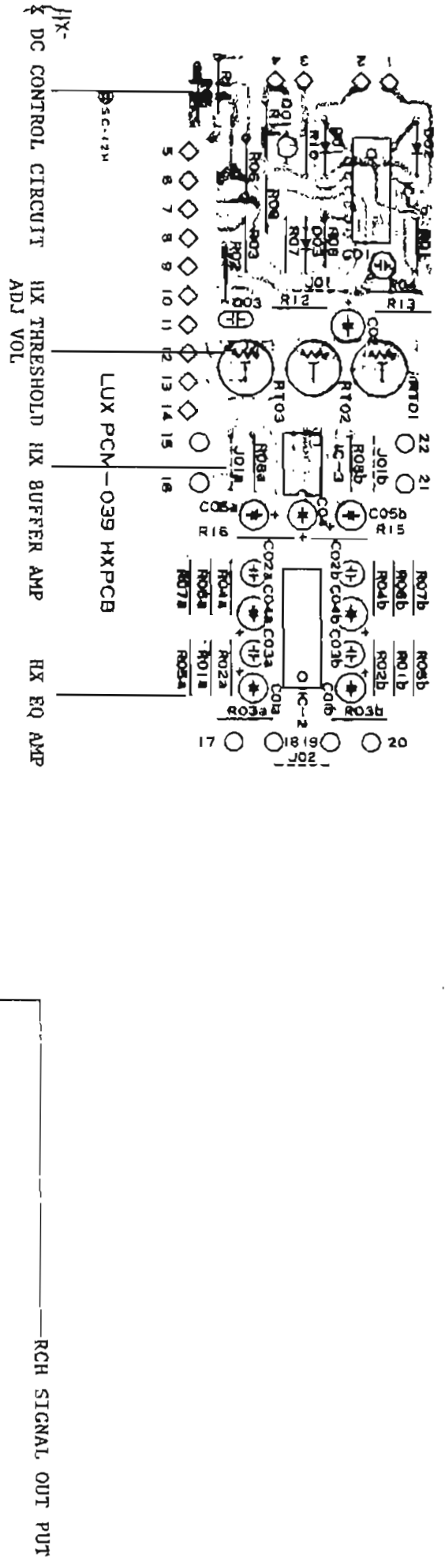

BILL OF MATERIAL PCM - 031 H. PH PCB Ass'y

SCHEMATIC REF. NUMBER	PART NUMBER	DESCRIPTION	NOTE	QUANTITY PER UNIT
	A - 0027	Phone Jack HLJD190-01-040		1
	B - 0001	Terminal Pin NH-49		4
	IC - 0021	IC LA4170		1
C01a, b	C - 0003	Electrolytic Capacitor SM25VB-4R7	4.7 μ /25V	2
C02a, b	C - 0003	" SM25VB-10	10 μ /25V	2
C03a, b, 06	C - 0003	" SM16VB-100	100 μ /16V	3
C04a, b	C - 0002	Polyester Film Capacitor AMS50-103K	0.01 μ /50V	2
C06	C - 0003	Electrolytic Capacitor SM25VB-33	33 μ /25V	1
R01a, b	C - 0016	Carbon Resistor CR25-104J	$\frac{1}{2}$ W 100K	2
R02a, b	C - 0016	" CR25-123J	$\frac{1}{2}$ W 12K	2
R03a, b	C - 0016	" CR25-399J	$\frac{1}{2}$ W 39 Ω	2
R04a, b	C - 0016	" CR25-159J	$\frac{1}{2}$ W 15 Ω	2

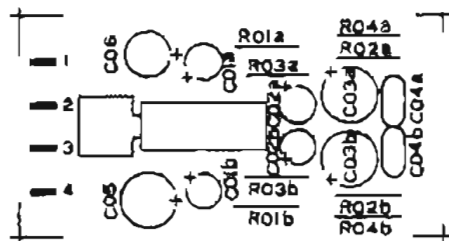

LUX PCM-031 HEAD PHONE PCB

BILL OF MATERIAL PCM - 004 KEY SW PCB Ass'y

SCHEMATIC REF. NUMBER	PART NUMBER	DESCRIPTION	NOTE	QUANTITY PER UNIT
	S - 0018	KEY Switch SCM81102		7
	A - 0031	Lamp 12V40mA		3
	YM - 0199	Bush - 3008		3

SYMBOL NO.	PART NUMBER	DESCRIPTION	NOTE	QUANTITY PER UNIT
1	YM-0438	Bottom Plate - 3003		1
2		Foot		4
3	YM-0428	Bonnet - 3004		1
4	YM-0299	Bonnet Himeron - 3011		2
5	YM-0448	Bonnet Himeron - 3013		1
6	YM-0421	Protector - 3009		1
7	YM-0422	Name Plate - 3006		1
8	YM-0423	Ornament Screw - 3063		2
9	YM-0425	Spacer - 3013		2
10	YM-0424	Stand - 3017		2
11	YM-0408	Panel - 3010		1
12	YM-0420	Protector - 3008		1
13	YM-0408	Name Plate - 3005		1
14	YM-0409	Escutcheon - 3002		3
15	YM-0381	Knob Set		1
16	SE-9610	Protector - 1066		1
17	YM-0171	Stand - 3005		2
18	YM-0410	Protector - 3007		1

SYMBOL NO.	PART NUMBER	DESCRIPTION	NOTE	QUANTITY PER UNIT
1	YM-0404	Sub. Panel - 3004		1
2	PCM-004	Key SW PCB Ass'y		1
3	YM-0352	Holder - 3035		1
4	M-0005	Meter LB-100-L14		1
5	YM-0413	Holder - 3038		1
6	M-0007	Counter Ass'y		1
7	YM-0440	Bushing - 3019		2
8	T-0046	LED SLP-1448		2
9	YM-0411	Meter Blind Plate - 3062		1
10	YM-0415	Holder - 3040		1
11	PCM-031	Phone Jack PCB Ass'y		1
12	A-0015	Nut HLJ0999-01-250		3
13	YM-0418	Holder - 3041		1
14	A-0015	MIC Jack HLJ0261-01-090		2
15	YM-0417	Holder - 3042		1
16	S-0026	Monitor SW SUF-12		1
17	YM-0414	Holder - 3039		1
18	S-0030	Flex Lever SW SLRW013		3
19	S-0028	Flex Wire L-360		1
20	S-0029	Flex Wire L-168		1
21	S-0031	Flex Wire L-234		1
22	V-0008	Bias Vol. VM10E-5KB		1
23	S-0025	Five Stretch SW SUF-41	Peak Hold, Counter, Reset Zero memory, Preset memory	1
24	PCM-033	VOL. PCB Ass'y		1
25	S-0032	Timer SW SRN1026N		1
26	S-0016	Power SW SDG5P-E	SK, SG, EK	1
	S-0014	Power SW SDG5P	UL, CSA	1
	S-0033	Power SW SDG1P	41-10714 ALPS	1
27	YM-0441	Extension Shaft - 3045		1
28	YM-0469	Holder - 4035		1
29	V-0009	Output Vol. GM80A-10KBX2		1
30	Z-0030	Cassette Mechanism FA83M010		1
31	YM-0487	Filter - 3001		1
32	YM-0430	Holder - 3043		1
33	YM-0418	Chassis - 3006		1
34	YM-0435	Side Panel - 3007		1
35	YM-0436	Side Panel - 3008		1
36	A-0009	Voltage Select Plug P2120-A		1
37	A-0008	Voltage Select Socket MI625		1
38	YM-0419	Channel - 3005		1
39	PCM-035	AMP PCB Ass'y		1
40	PCM-037	Fuse PCB Ass'y (1)		1
41	PCM-038	Fuse PCB Ass'y (2)	SEMKO	1
42	PCM-034	LOGIC PCB Ass'y		1
43	PCM-036	LOGIC P.S PCB Ass'y		1
44	YM-0488	Holder - 3047		1
45	YM-0437	Chassis - 3007		1
46	YM-0433	Holder - 3044		1
47	P-0013	Power Trans.	SK, SG	1

SYMBOL NO.	PART NUMBER	DESCRIPTION	NOTE	QUANTITY PER UNIT
	P-0014	Power Trans.	EJ, EZ, EK	1
48	PCM-039	HX PCB Ass'y		1
49	YM-0432	Back Panel - 3004		1
50	A-0026	Power Cord VW-1	EZ	1
	A-0004	Power Cord	EJ	1
	A-0016	Power Cord C-2-4610	EK, SK	1
	A-0025	Power Cord VRF-777	SG	1
51	SE-9092	Label - 1131		1
	YM-0482	Seal - 3011 100V		1
	SE-10618	Seal - 1272 220V		1
	SE-10618	Seal - 1275 240V		1
	SE-10934	Seal - 1300 120V		1
	SE-11628	Seal - 1359	SEMKO, DEMKO	1
52	B-0008	Cord Stopper 4N-4		1
	B-0007	Cord Stopper 5N-4	SG	1
53	A-0028	Pin Jack AKB-0570		1
54	A-0007	Remote Connector S-1612A		1
55	A-0007	Remote Connector P-1612A-ST		1
56	YM-0074	Holder - 3008		1
57	YM-0431	Channel - 3008		1
58	YM-0461	Blind R-3065		1
59	YM-0184	Mold Knob - 3002	Eject	1
80	YM-0070	Switch Knob - 3002	Peak Hold, Reset, Monitor Zero memory, Preset memory	5
61	YM-0240	Mold Knob - 3005	Bias line	1
62	SE-8946	Mold Knob - 1077	Timer	1
63	YM-0392	Knob Set - 3005	MIC, LINE	2
	YM-0454	Knob Set - 3010	EJ, LAA	2
64	YM-0183	Mold Knob - 3003		3
65	YM-0427	Knob Set - 3008		1
	YM-0426	Knob Set - 3007	LAA, EJ	1
66	SE-11277	Mold Knob - 1121	LAA, ET	3
	YM-0453	Mold Knob - 3009		3
67	SE-9607	Mold Knob - 1089		1
68				
69				
70	M2.6 x 6	Binding Head Tapping Screw	ZMC	3
71	M3 x 8	"	ZMC	77
72	M3 x 8	"	ZMC	2
73	M4 x 6	"	ZMC	6
74	M4 x 10	"	ZMC	4
75	M3 x 4	Binding Head Screw	ZMC	22
76	M4 x 6	"	ZMC	4
77	M2 x 4	"	BLACK	4
78	M3 x 4	"	BLACK	11
79	M3 x 8	"	BLACK	1
80	M3 x 6	Binding Head Tapping Screw	BLACK	12
81	M3 x 12	Binding Head Screw	NI	1
82				
83	M3	Hexagon Nut	ZMC	1

SYMBOL NO.	PART NUMBER	DESCRIPTION	NOTE	QUANTITY PER UNIT
84	3 x 8 x 0.5	Washer	NI	1
85	2.9 x 7.5 x 0.5	"	ZMC	3
86	3 x 0.5	Polyslider Washer		1
87	2 x 0.13	"		2
88	8-0016	Bind metal		21
89		Free Bush		1
90	3 x 7 x 0.5	Washer	BLACK	1
91	M3 x 10	Binding Head Tapping Screw	BLACK	2

BILL OF MATERIAL

F/A 83M 010

SYMBOL NO.	PART NUMBER	DESCRIPTION	NOTE	QUANTITY PER UNIT
1	1A42045U01	Ass'y, Riv. Bkt. Door		1
2	43A42035U01	Spacer, Door		2
3	3S44205G04	Scr.. Tpg. M3 x 0.5 x 5		8
4	30S43803G05	Dial Cord		1
5	4C42091G05	Washer C		9
6	1A42944F01	Ass'y, Riv. Bkt. Door L		1
7	37S44488G16	Vinyl Tube		1
8	Not Used			
9	Not Used			
10	46A42942F01	Lever, Eject		1
11	4S40070G05	Washer 3.3 x 8 x 0.5		1
12	41B41497U13	Spring Pull		1
13	1A42054U01	Ass'y, Frame Door		1
14	15C41130U01	Holder, Chassis		1
15	15C41130U01	Holder, Chassis		1
16	1B42046U01	Ass'y, Riv. Arm Door		1
17	1B42046U01	Ass'y, Riv. Arm Door		1
18	1A42951F01	Ass'y, Riv. Support Chassis		1
19	61A41185U01	Lens Back Light		1
20	7A41942U01	Bkt. Micro Sw.		1
21	7A41944U01	Bkt. Record Sencor		1
22	45B42011U01	Arm, Sw.		1
23	47A41173U02	Shaft, Record Sensor		2
24	41B41492U12	Spring, Pull		2
25	3S40011G85	Mch. Scr. M2 x 0.4 x 15		2
26	1A42047U01	Ass'y, Riv. Base HD.		1
27	48B41972U01	Block, HD		1
28	3S42155U01	Screw, Set (-)		2
29	3S40019G08	Screws M2 x 0.8 x 10		1
30	3C40014G07	Mch. Screw M2 x 0.4 x 4		2
31	41A41490U01	Spring, Azimuth		1
32	3C40014G04	Mch. Screw M3 x 0.5		10
33	7A41971U01	Bkt. Motor		1
34	49A42113U01	Pulley, Motor		1
35	Not Used			
36	3C40121T04	Screw, Mch. M2.6 x 7		8
37	43A41289U02	Sleeve, Cushion		6
38	75A41885U01	Cushion, Motor		7
39	22B40232G02	Pin Spring		2
40	7A41950U01	Bkt., Solenoid M		1
41	48A41940U01	Stopper, Plunger		1
42	1A42050U01	Ass'y, Riv. Lever Solenoid		1
43	1B42042U01	Ass'y, Riv. Sub Chassis		1
44	44B40208T01	Gear Drive		1
45	44B40207T01	Gear Drive		1
46	Not Used			
47	4A41345P01	Washer Lock		2
48	Not Used			
49	Not Used			
50	3A411U01	Screw, Bearing		2

SYMBOL NO.	PART NUMBER	DESCRIPTION	NOTE	QUANTITY PER UNIT
51	7A41938U01	Bkt., Pinch Roller		1
52	45A41938U01	Arm, Idler A		1
53	45A41939U01	Arm, Idler B		1
54	45A41946U01	Arm, Chassis Holder		1
55	41A41947U01	Spring, Head Base		1
58	Not Used			
57	49A41954U01	Flywheel, Capstan L		1
58	49B41955U01	Flywheel, Capstan R		1
59	16A41966U01	Housing, Capstan		2
60	45A41958U01	Cam, Clutch Idler		1
61	45A41958U01	Link, Fwd.		1
62	42A41960U01	Belt, Motor		1
63	42A41961U01	Belt, Sub		1
64	Not Used			
65	7A41963U01	Bkt., Pinch Roller		1
66	45B41935U01	Lever, Brake		1
67	45T41964U01	Clutch, Play		1
68	45T41967U01	Clutch, FF		1
69	49T41970U01	Pulley, FF Idler		1
70	43A41096U01	Guide Cassette		2
71	49T41829F01	Reel, Take Up		1
72	49T41448U01	Reel, Supply		1
73	49A42898U01	Wheel, Tention A		1
74	49B42899U01	Wheel, Tention B		1
75	45A41096U01	Arm, Brake		2
76	43A41182P02	Ball Steel		5
77	41A42895U02	Spring, Push		1
78	41A41491U02	Spring, Push		1
79	41A42109U01	Spring, Cam Clutch		1
80				
81	41A42111U01	Spring, Clutch		1
82	41A42112U01	Spring, Arm Idler		1
83	41A42114U01	Spring, Pully Idler		1
84	43A42040U01	Sleeve, Idler Shaft		1
85	43A42023U01	Sleeve		2
86	41B43678U02	Spring, Pull		1
87	43A42115U01	Spacer, Head Base		2
88	41B41492U03	Spring, Pull		2
89	41B41492U05	Spring, Pull		1
90	41B43678U06	Spring, Pull		1
91	41B43676U01	Spring, Pull		1
92	2S40000G12	Nut Hex, M3 x 0.5		2
93	41B44327P07	Spring, Pull		1
94	65C42544U02	Lamp, Pilot		1
95	40C43472J01	Micro Sw. S		2
96	4A41345P02	Washer Lock		2
97	4A41345P03	Washer Lock		3
98	4A41345P05	Washer Lock		2
99	4S40075G07	Washer P. S.		1
100	4S40075G10	Washer P. S.		2

SYMBOL NO.	PART NUMBER	DESCRIPTION	NOTE	QUANTITY PER UNIT
101	43A44303P01	Washer Oil Shield		2
102	3S44205G03	Screw Tap Tite M3 x 8		2
103	1C42041U01	Ass'y, Riv. Chassis		1
104	1A41990U01	Ass'y, Bkt. Pinch Roller		1
105	1A42048U01	Ass'y, Riv. Cam		1
106	1A42947F01	Ass'y, Riv. Stopper Eject		1
107	1A42051U01	Ass'y, Riv. Lever Solenoid Main		1
108	1A41516U01	Ass'y, Pinch Roller		1
109	43B43738U01	Tape, Guide		1
110	3S40019G03	Screw, F-Locks		2
111	41B43676U03	Spring Pull		1
112	41A43688U01	Spring Cord		1
113	41A43685U01	Spring Oumper		1
114	3S40019G32	Screw, F-Lock		4
115	88T42854F01	Head, R/P Combi		1
116	4S40075G18	Washer, S. T. W.		4
117	41A43875U01	Spring, Pinch Push		1
118	41A42351U02	Spring, Pinch Roller Br		1
119	88T44524U01	Head, Erase		1
120	3S40019G01	Screw, F-Lock		1
121	59T42144U01	Motor DC		
122	4S40075G12	Washer 3.1 x 5.4		1
123	59T42145U01	Motor DC		1
124	4C42091G05	Washer "C"		6
125	75A44238P01	Pad Brake		1
126	4S40075G05	Washer 2.1 x 4 x 0.13		2
127	4S40011G75	Mch., Scr M2 x 0.4 x 14		1
128	4S40075G19	Washer 4 1 x 8 5 x 0.5		6
129	3S40019G28	Scr., F-Lock		10
130	4S40075G13	Washer S. T. W.		2
131	29A737272	Lug Wrap Around		1
132	48C40235U01	Diode 10E1		2
133	43A43689U01	Sleeve Idler Shaft		1
134	48S42931U23	Thermistor		1
135	3S44205G01	Scr., Tpg. M3 x 0.5 x 6		4
136	3S44205G12	Scr., T. M3 x 4		5
137	4C42091G06	Washer "C"		3
138	4S40075G08	Washer S. T. W.		3
139	4S40075G24	Washer		2
140	75A44231U01	Cusion HD. Base		1
141	42A44230U01	Lug, Wrap Through		1
142	41A44528U01	Spring Flywheel		1
143	41A40594F01	Spring Eject Lever		1
144	3C40014G08	Mch., Scr., M2.6		1
145	1V42600F01	Ass'y, Panel Term		1
146	1V42600F41	Ass'y, Photo Sensor		1
147	15A41630F01	Cover Sensor		1
148	1T42117U01	Ass'y, Solenoid		1
or	1T42752U01	Ass'y, Solenoid		1
149	1T42119U01	Ass'y, Solenoid		1
or	1T42754U01	Ass'y, Solenoid		1

SYMBOL NO.	PART NUMBER	DESCRIPTION	NOTE	QUANTITY PER UNIT
-		(Ass'y, Photo Sensor)		
	84A41631F01	Panel, Sensor		1
	48T41832F01	L. E. D.		1
	48T41633F01	TR. Photo		1
		(Ass'y, Panel Terminal)		
	84B43706U01	Panel, Terminal		1
	48T40412F01	Resistor 47		1
	48C40235G01	Diode 10E1		1
	6S41802P19	Res., F.C. 82 - 1/4		1
	6D40802G84	Res., F.C. 33 - 1/2		1
	6S41801P31	Res., F.C. 820 - 1/4		1
	6S41801P34	Res., F.C. 1.5K - 1/4		1

EXPLANATION OF K-15 AMP CIRCUIT OPERATION

1. PB/EQ Operation

a. Circuit configuration

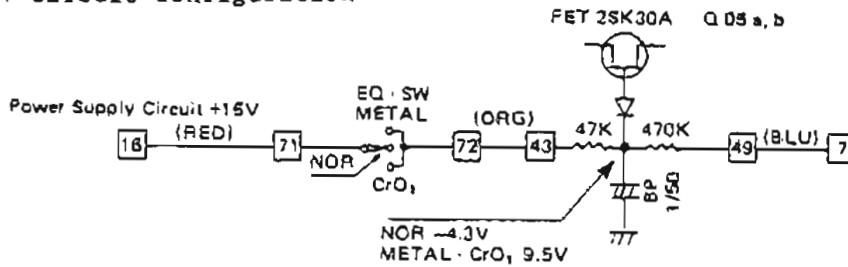

b. Circuit operation

FET turns off when EQ Sw is set at NOR; it turns on when EQ Sw is set at METAL or CrO₂. The PB and EQ circuits operate as shown in the figure.

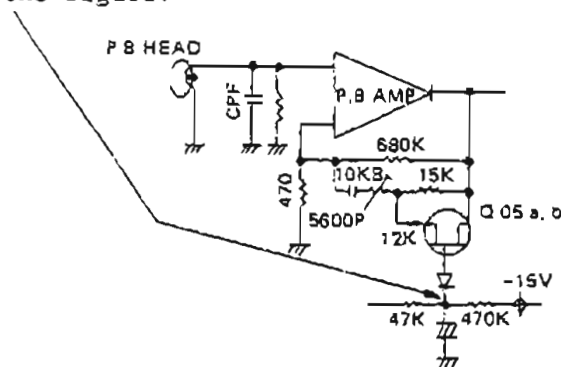

A pair of FETs are required for the PB amp differential circuit (ΔV_{GS} selection)

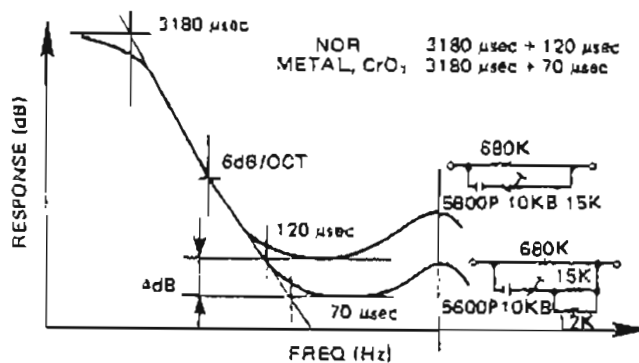

Peak frequency is determined both by "L" of the head "C" of the resonance capacitor; rise in frequency response is determined both by "Q" of the head and the input impedance of the amp.

2. Dolby NR ON-OFF Control Circuit

a. Circuit configuration

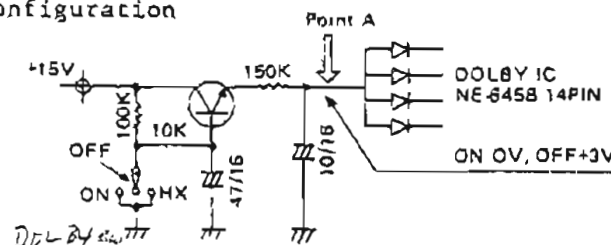

b. Circuit operation

Voltage change at point A

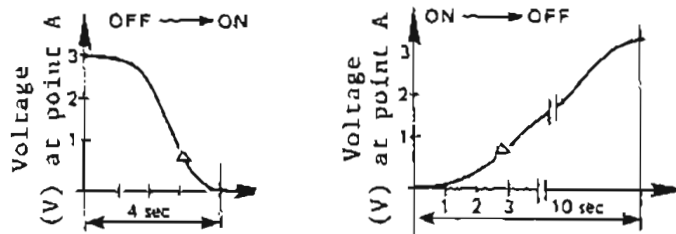

When a direct current is applied to the Dolby IC 14 pin, the Dolby circuit operates as if it received a large input signal, and the Dolby encoder/decoder characteristics do not work out. To eliminate a click caused by the abrupt application of DC voltage. ON-OFF time constant is determined to about 3 seconds.

3. REC Mute Operation

a. Circuit configuration

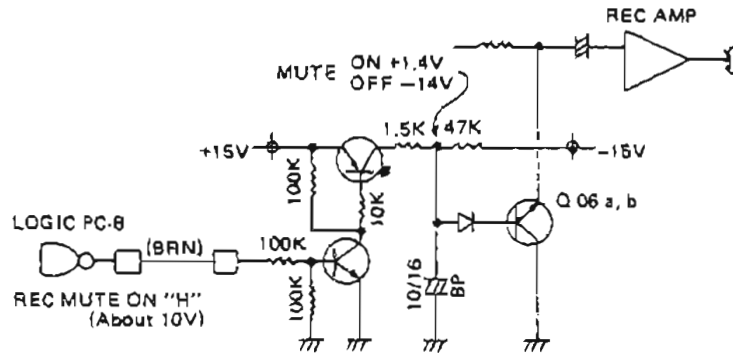

b. Circuit operation

Time constant of muting ON-OFF is almost zero.

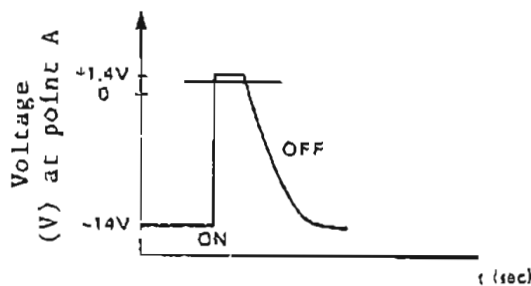

Transistors Q06 and Q07 turn on when voltage exceeds +1.2V at point A.

4. Muting Circuits

a. Circuit configuration

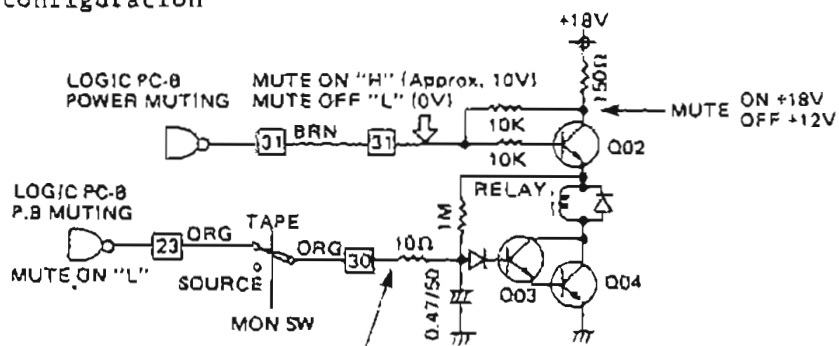

1.8V develops when in the PLAY/REC mode (MUTE: OFF).

b. Circuit operation

(1) Power-OFF muting

When power is switched off, the power-OFF muting circuit turns Q02 off to mute clicks on the fall of respective amp signals.

Voltage waveform across the relay is shown below (tape monitor and timer/play on).

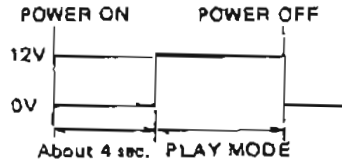

(2) PB muting

PB muting is provided by depressing the stop or pause key with the MON Sw set at TAPE. In addition, when power is switched on, another muting is provided until respective amps stabilize.

5. Bias OSC ON-OFF Control Circuit

a. Circuit configuration

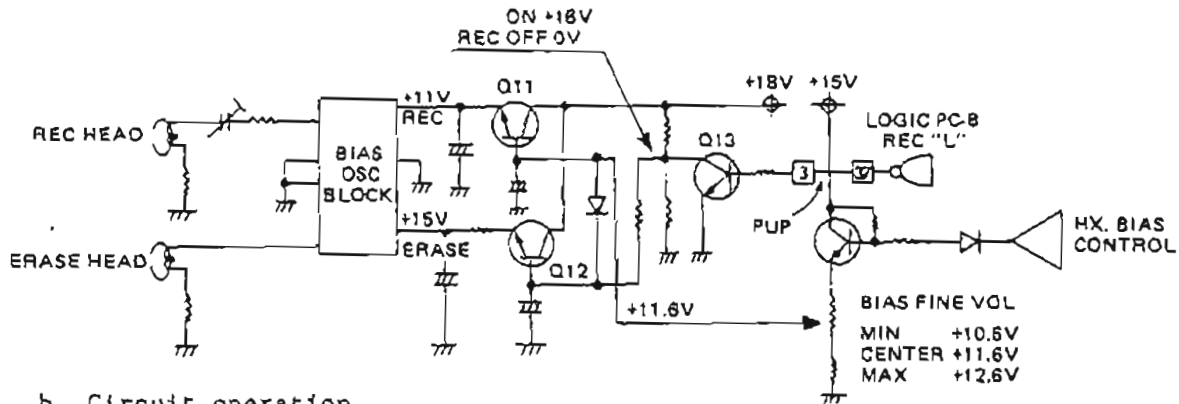

b. Circuit operation

The bias OSC block consists of a recording bias oscillator and an erase oscillator. The recording bias oscillator is controlled by transistor Q11 while the erase oscillator, by transistor Q12. A bias current is controlled by varying the base voltage of Q11 by the bias fine vol. Therefore, the erase head's current is not affected by moving the bias fine vol.

6. REC EQ

a. Circuit configuration

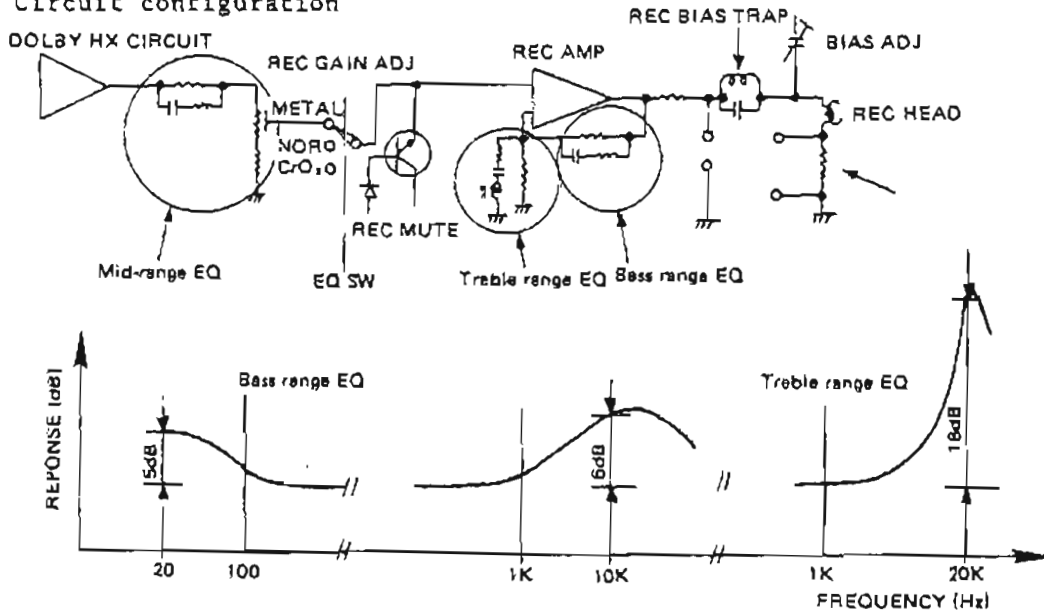

b. Circuit operation

EQ (recording equalization) may be represented by the solid line in the below figure. Without EQ, frequency response may be shown by the dotted line. EQ must differ with the types of tapes and be determined according to EQ Sw setting, METAL, CrO₂ or NOR.

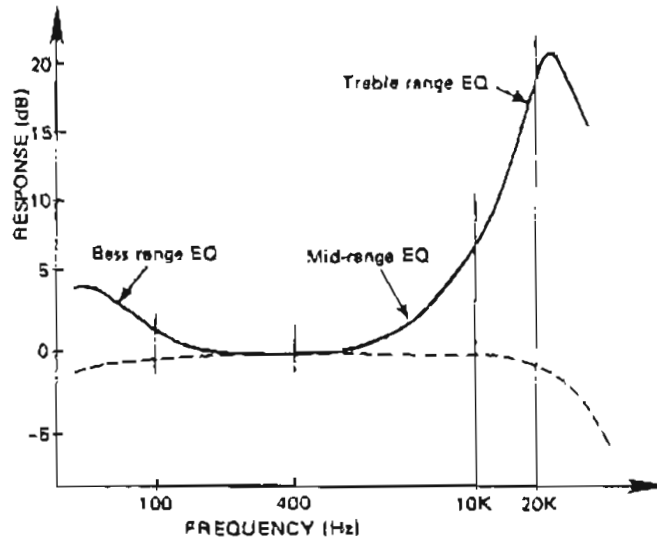

7. Dolby Circuit

a. Circuit configuration

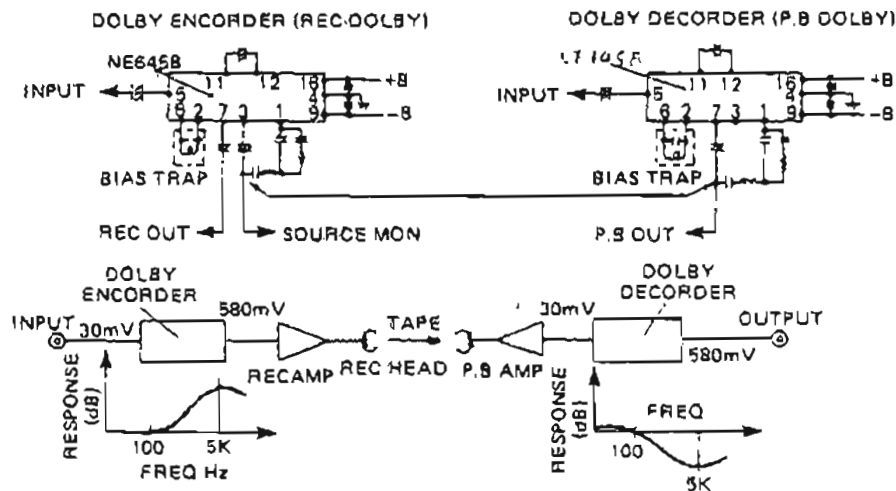

b. Circuit operation

If recording level is raised in the treble range and if the playback level is then lowered inversely as shown in the above figures, tape hiss will be reduced with the Dolby Sw on accordingly. This noise reduction method, however, is not effective for noises inherent to the REC amp, musics, and sources.

As shown by the frequency response curves of the Dolby encoder/decoder in the above figures, an amount of compensation decreases with rise in recording level, so that the curves go flat at 0VU (200 nWb/m) recording level. In order to positively alter an amount of compensation in accordance with this level, it is necessary to adjust Dolby output level to 580mV. In addition, in the X15 cassette deck, optimum encode characteristics have been selected according to the variance of Dolby ICs, which are marked orange, red, white, yellow or green for pairing.

8. Dolby Hx Circuit

a. Circuit configuration

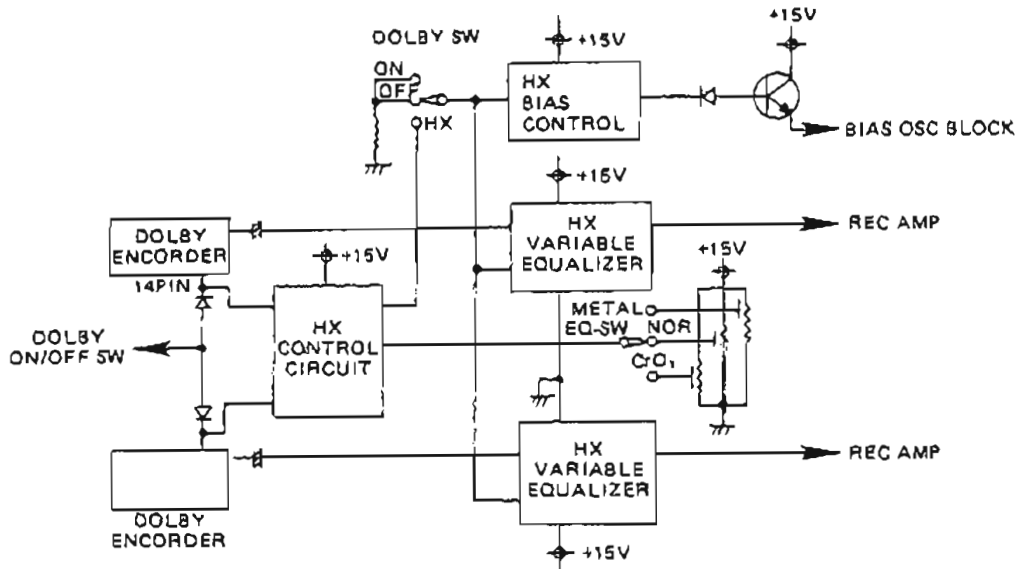

b. Circuit operation

The instant an input signal happens to contain abnormal treble range characteristics, the Dolby Hx circuit will reduce recording bias and an amount of compensation at the same time, thereby improving treble-range characteristics. The Dolby Hx circuit uses a conventional signal from the Dolby NR IC as a control signal. The circuit configuration includes a control circuit, variable equalizer circuit, and variable bias circuit.

Sample treble range characteristics improved by the Dolby Hx system

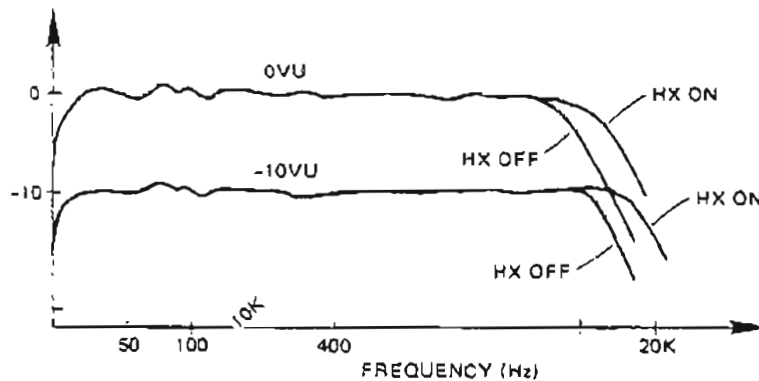

A newly designed bias OSC block has been introduced together with the Dolby Hx system because a conventional bias OSC circuit allows an erasure current to change when the recording bias is changed, thus causing a failure in erasure. The new bias OSC block contains two oscillators, one for recording bias and the other for erasure.

Explanation of Mechanism Control Circuit

1. Logic control circuit

1-1. The supply voltage V_{CC} to the logic circuit is +10V.

"H" level means +9 to 10 V.

"L" level means 0 to +1 V.

1-2. Logic Tables and packages (top view) of ICs used

1) 74C04



Input	Output
L	H
H	L

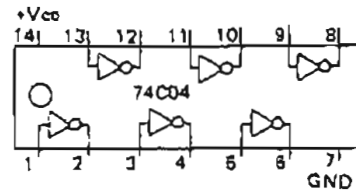

2) 74C00

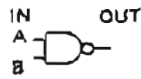

Input A	Input B	Output
L	L	H
L	H	H
H	L	H
H	H	L

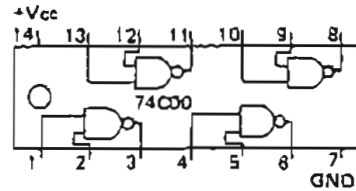

3) 74C08

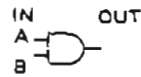

Input A	Input B	Output
L	L	L
L	H	L
H	L	L
H	H	H

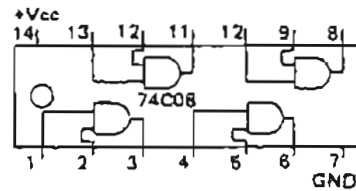

4) TC9121P (IC6)

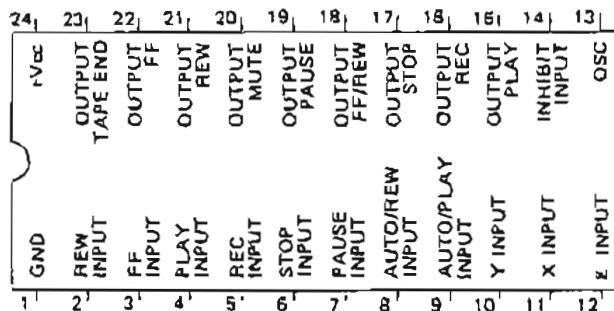

1-3. Fundamental operation

A key input to the logic circuit is pulled up to "H" at all times, and is switched to "L" by a keystroke. Key input signals are stored in TC9121P, and are output as drive signals for respective operating modes. The logic table of modes is shown in Table 1.



Table 1

Mode Symbols

REC : Record

FF : Fast forward

REW : Rewind

KEY CONTROL TEST POINT	STOP KEY	PAUSE KEY	REC KEY PLAY KEY	PAUSE KEY	REC MUTE KEY	REW KEY	F.F. KEY	PLAY KEY	PAUSE KEY
	STOP	STOP PAUSE	REC PAUSE	REC	REC	REW	F.F.	PLAY	PLAY PAUSE
ICB-18 OUTPUT PLAY	L	L	L	H	H	L	L	H	L
ICB-18 OUTPUT REC	L	L	H	H	H	L	L	L	L
ICB-19 OUTPUT PAUSE	L	H	H	L	L	L	L	L	H
ICB-20 OUTPUT MUTE	H	H	L	L	L	H	H	L	L
ICB-21 OUTPUT REW	L	L	L	L	L	H	L	L	L
ICB-22 OUTPUT F.F.	L	L	L	L	L	L	H	L	L
LOGIC PCB PIN 41 PLAY	L	L	L	H	H	L	L	H	L
PIN 46 REW MARKER	L	L	L	L	L	H	L	L	L
PIN 48 F.F.	L	L	L	L	L	L	H	L	L
PIN 28 PLAY LAMP	L	L	H	H	H	L	L	H	H
PIN 27 PAUSE LAMP	L	H	H	L	L	L	L	L	H
PIN 28 REC LAMP	L	L	H	H	H	L	L	L	L
PIN 23 P/B MUTE	L	L	L	H*	H*	L	L	H*	L
PIN 37 REC BIAS	H	H	L	L	L	H	H	H	H
PIN 38 REC MUTE	H	H	H	L	H	H	H	H	H
PIN 44 TAPE END ENABLE	L	L	L	H	H	H	H	H	H
PIN 43 COUNTER UP/DOWN			H	H	H	L	H	H	H
PIN 40 Δ MARKER	L	L				L	H		

(NOTE) H* : "H" level is 1.2V with the tape monitor ON.

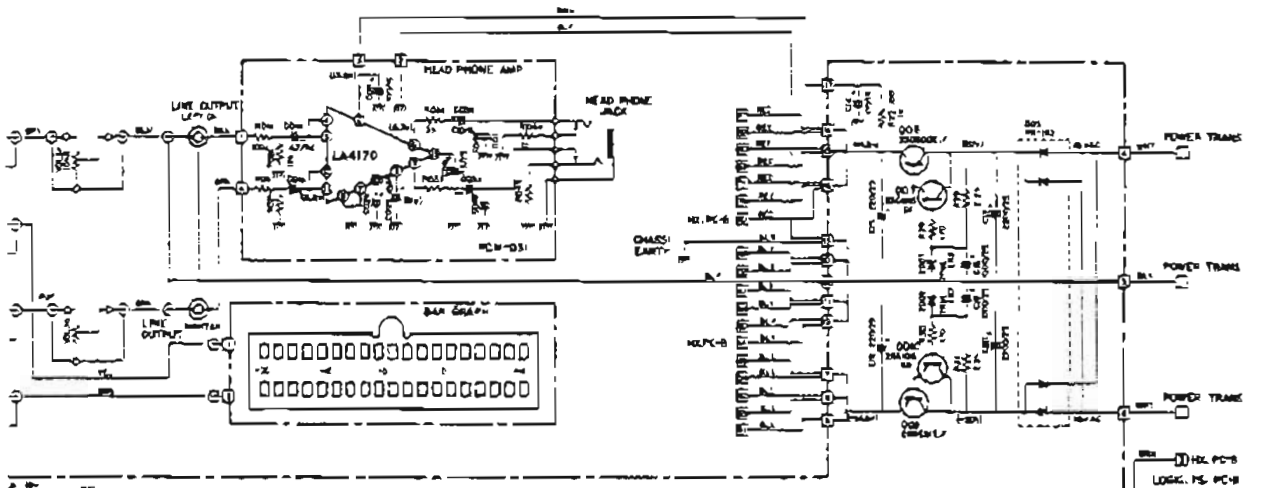

AMP PC-B
PCM-035

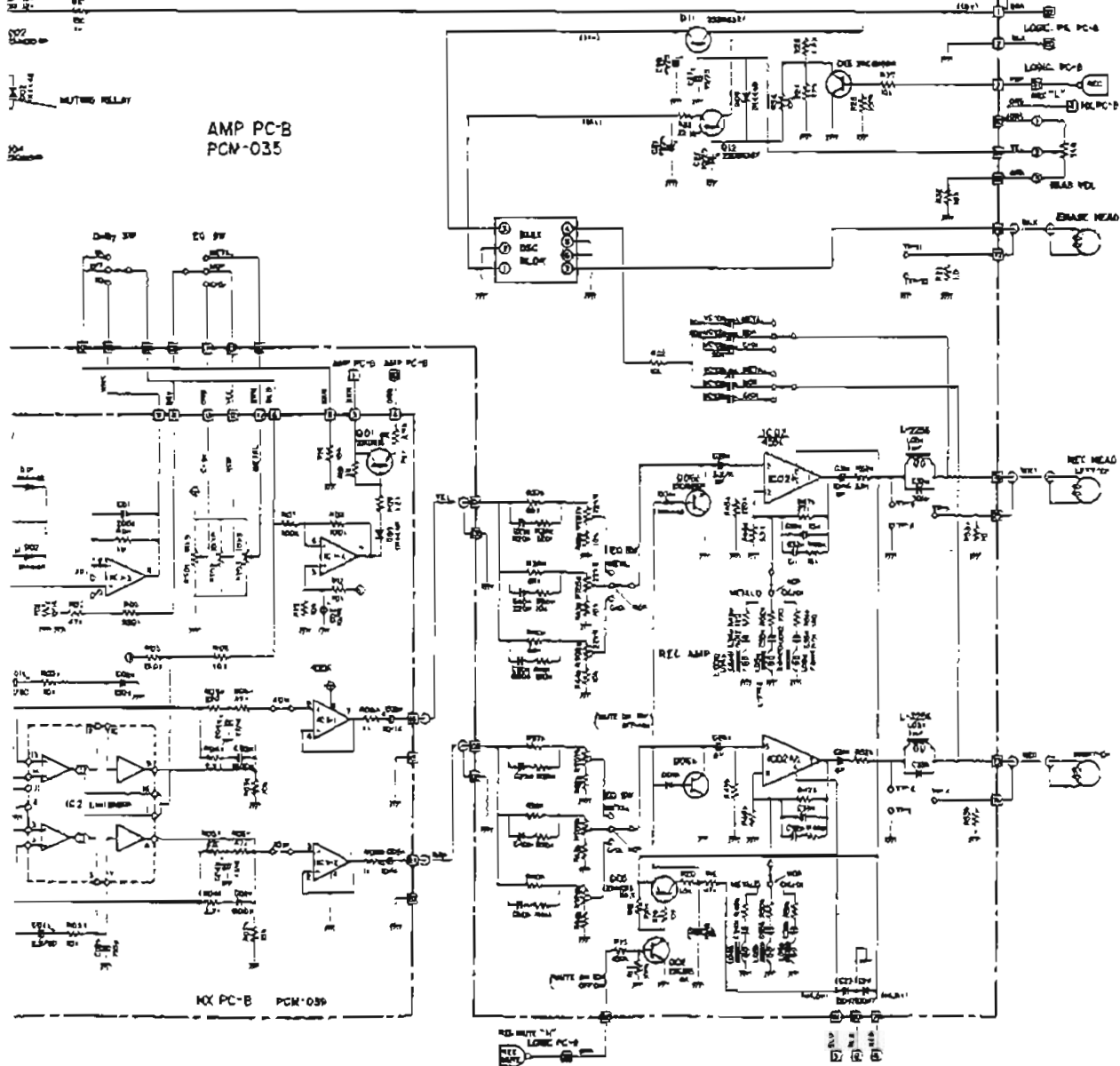

MIX PC-B
PCM-035

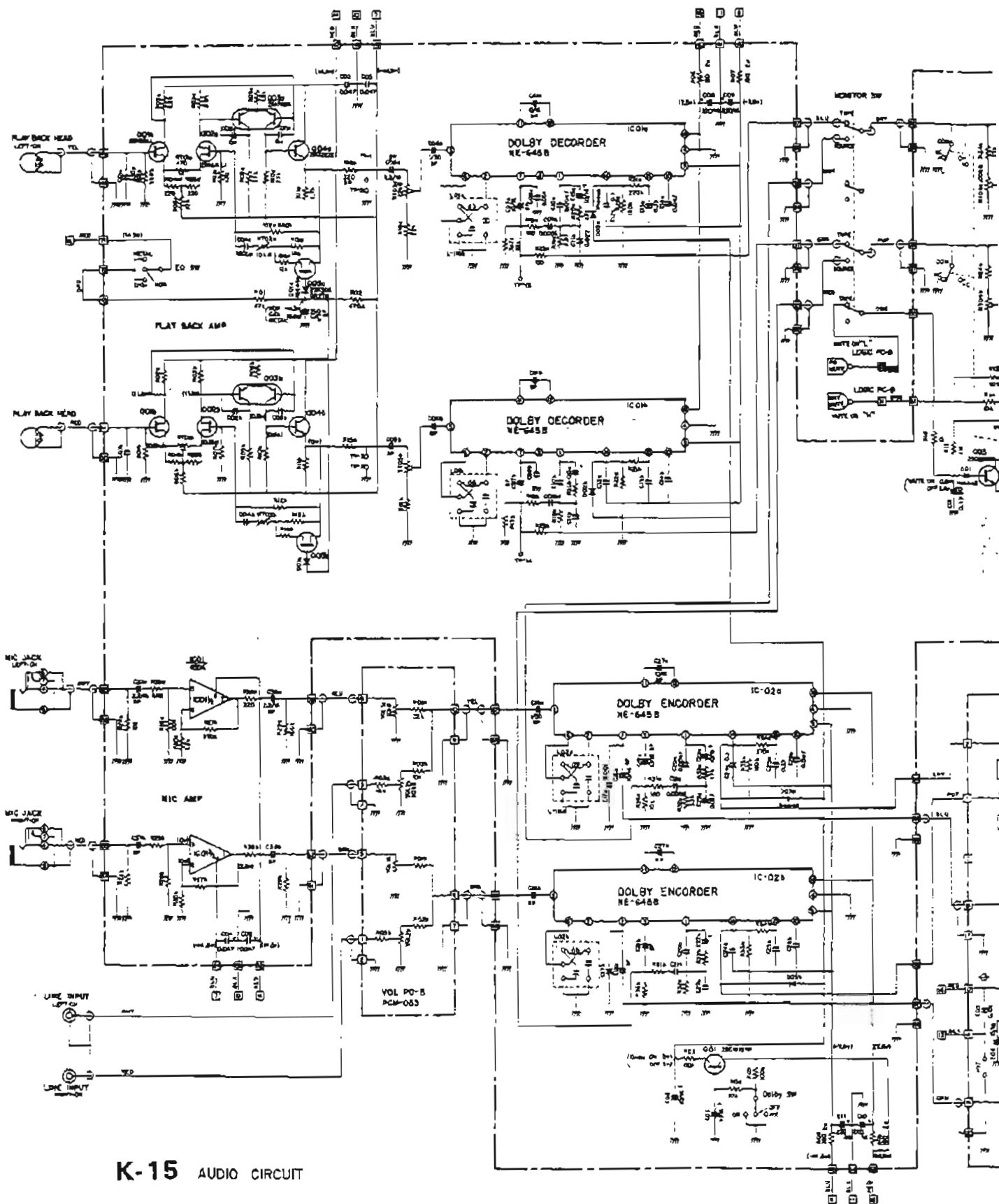

K-15 AUDIO CIRCUIT

Tape Position Control Timing for REC/Pause "ON"

When Q03 turns on in the REC mode and the pause button is depressed, the tape is backed off a little by delaying the off timing of the secondary solenoid driver.

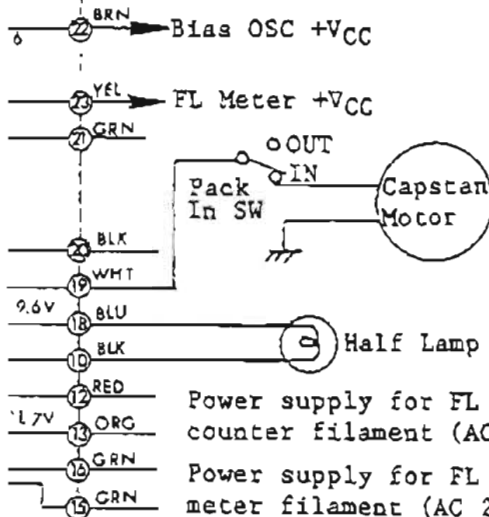

Loading a cassette will turn on the pack-in Sw and start the capstan motor.

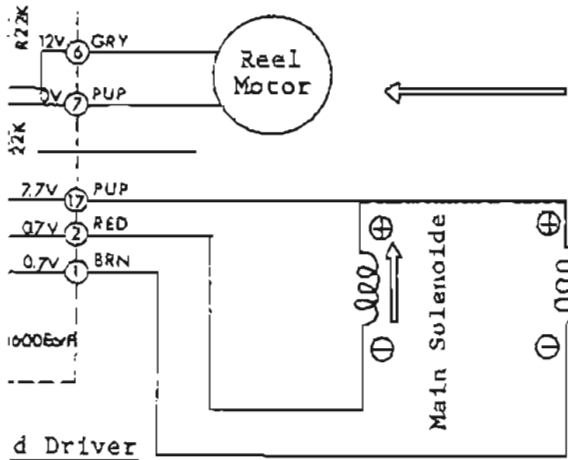

Reel motor terminal voltage

Mode \ VDC	FF	Rew	Play or Rec
⑥	0V	14V	13.5V
⑦	14V	0V	0V

PLAY or REW signal goes "H".

Timing voltage waveform occurs across solenoid on the rise of the REC mode. Pin, Cold 2 Pin

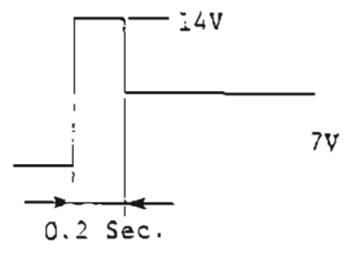

3. Explanation of motor and solenoid drive circuit operation

These circuits receive PLAY, FF, or REW output signals from the logic circuit, and drive the reel motor, main and secondary solenoids.

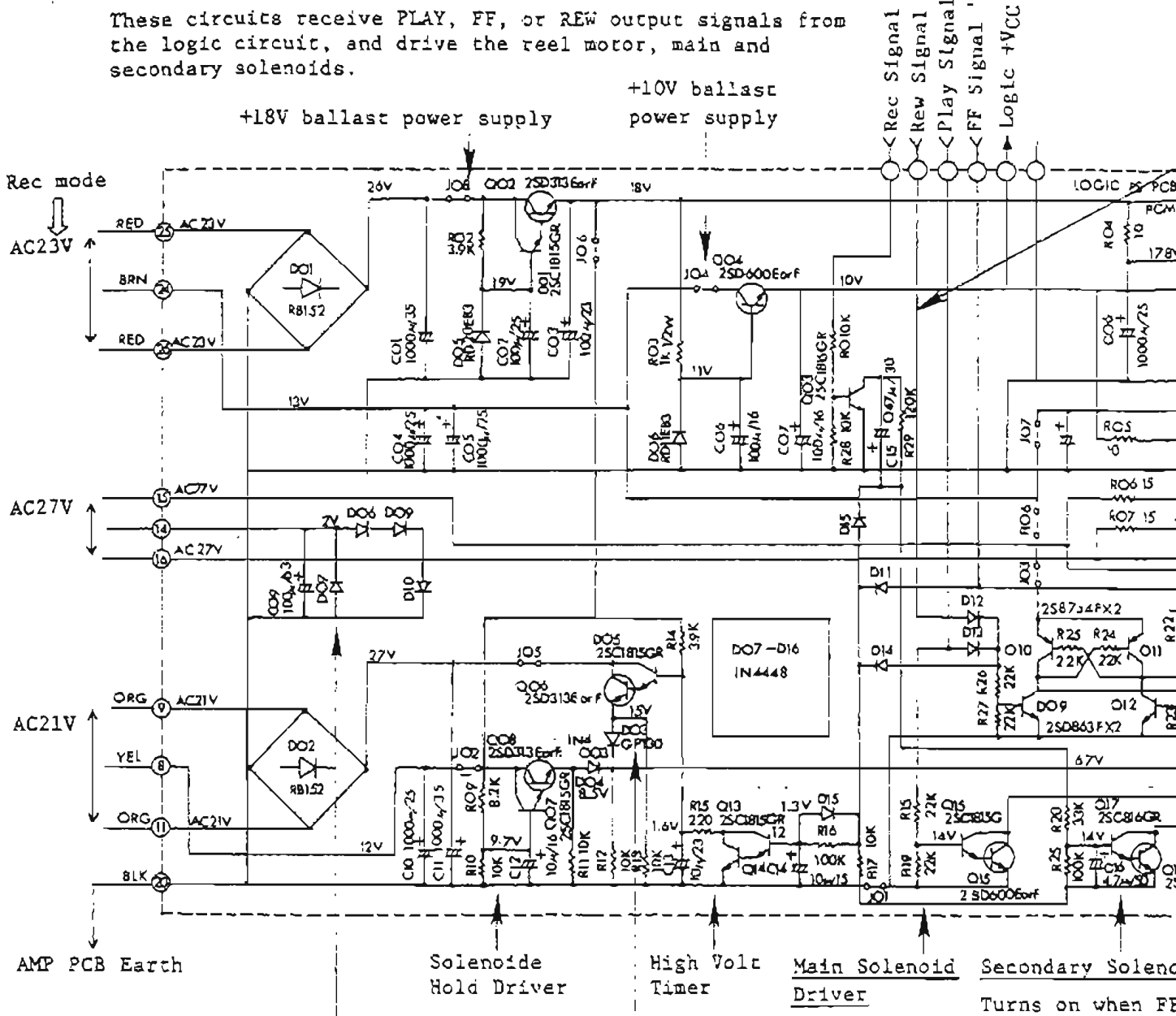

The center tap of the FL meter filament winding is pulled up to +2 VDC.

Solenoid High-voltage Driver

A high voltage (about 14 V) is applied for 0.2 sec. to the HOT side of the solenoid on the rise of the FF, PLAY, or REW signal.

Turns on when the play signal goes "H".

The foll the main Hot 17

2. Explanation of tape counter circuit operation

Counter action

The revolution of the take-up reel is optically detected. The counter is tripped one count by five detecting pulses.

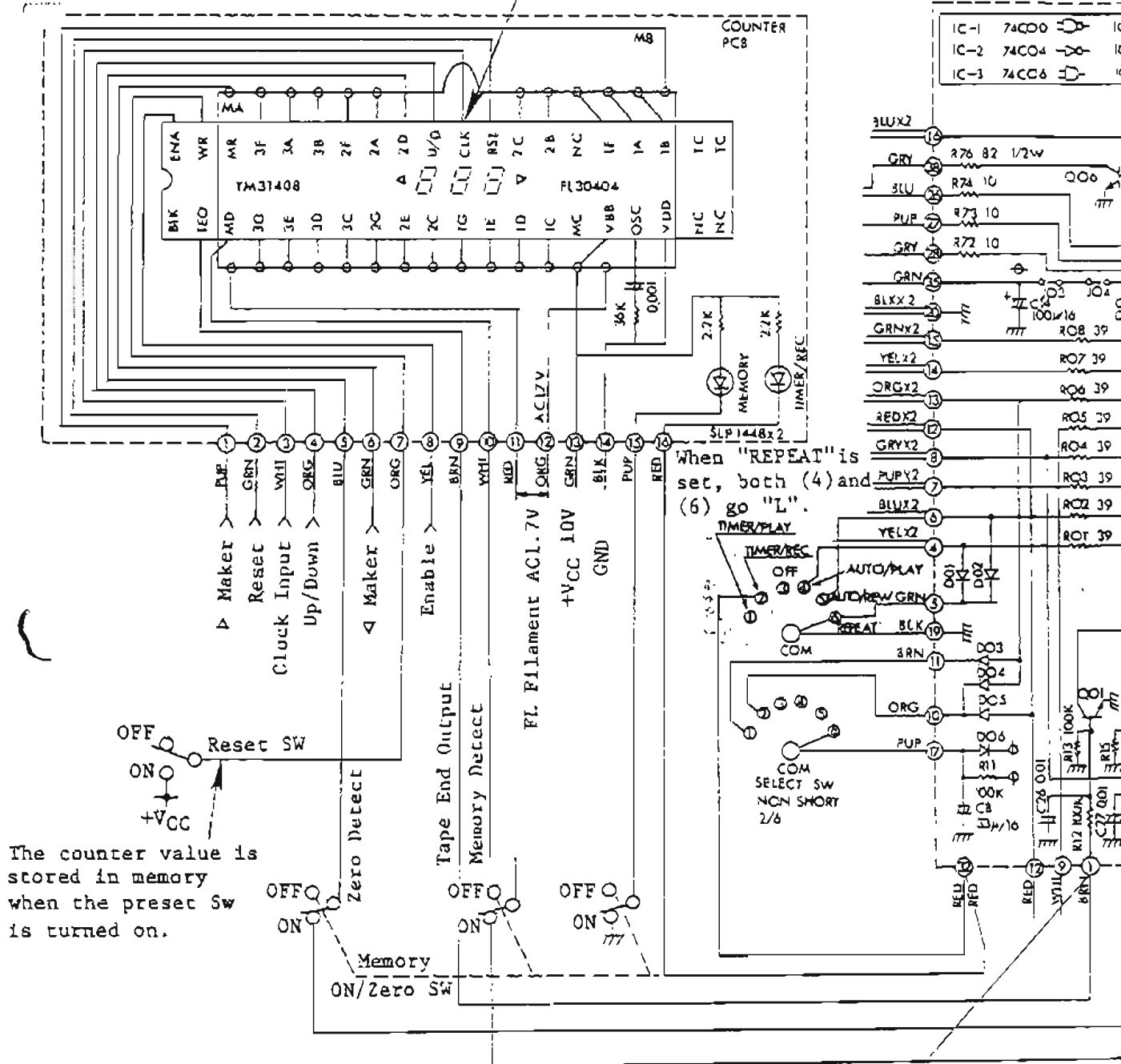

The counter value is stored in memory when the preset Sw is turned on.

Tape End Auto Stop

The following waveform is applied when tape end is detected in the PLAY, FF, or REW mode.

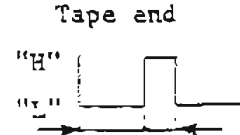

About 3 Sec., 150m Sec.

Acts as AU pin when t... The follow only in th... Counter ze

Delays FF rise-time by 0.4 sec.
 Delays REW rise-time by 0.4 sec.
 Delays PLAY rise-time by 0.4 sec.

REC MUTE TIMING

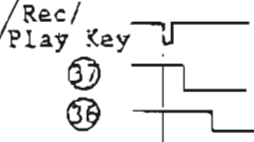

Power-OFF Mute

The following waveform occurs when the power switch is turned off.
 Powr OFF

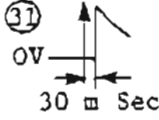

PB Mute Timer

The following rise waveform occurs when the PLAY key is depressed with the tape monitor on.

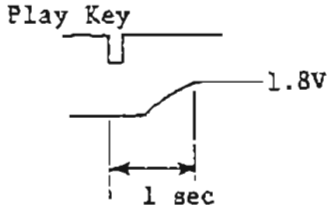

OFF Counter Reset Sw

Resets the counter at "H".
 Resets the meter peak hold at "L".

Hold Meter Plak Hold SW

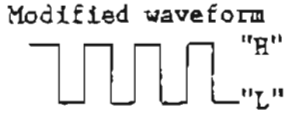

Reel revolution detection waveform
 6V or Higher
 2V or Lower

Reel signal level shift

Output timing for a keystroke is as follows:

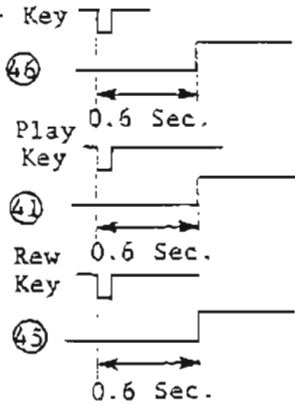

N4448
 15C 1815GR

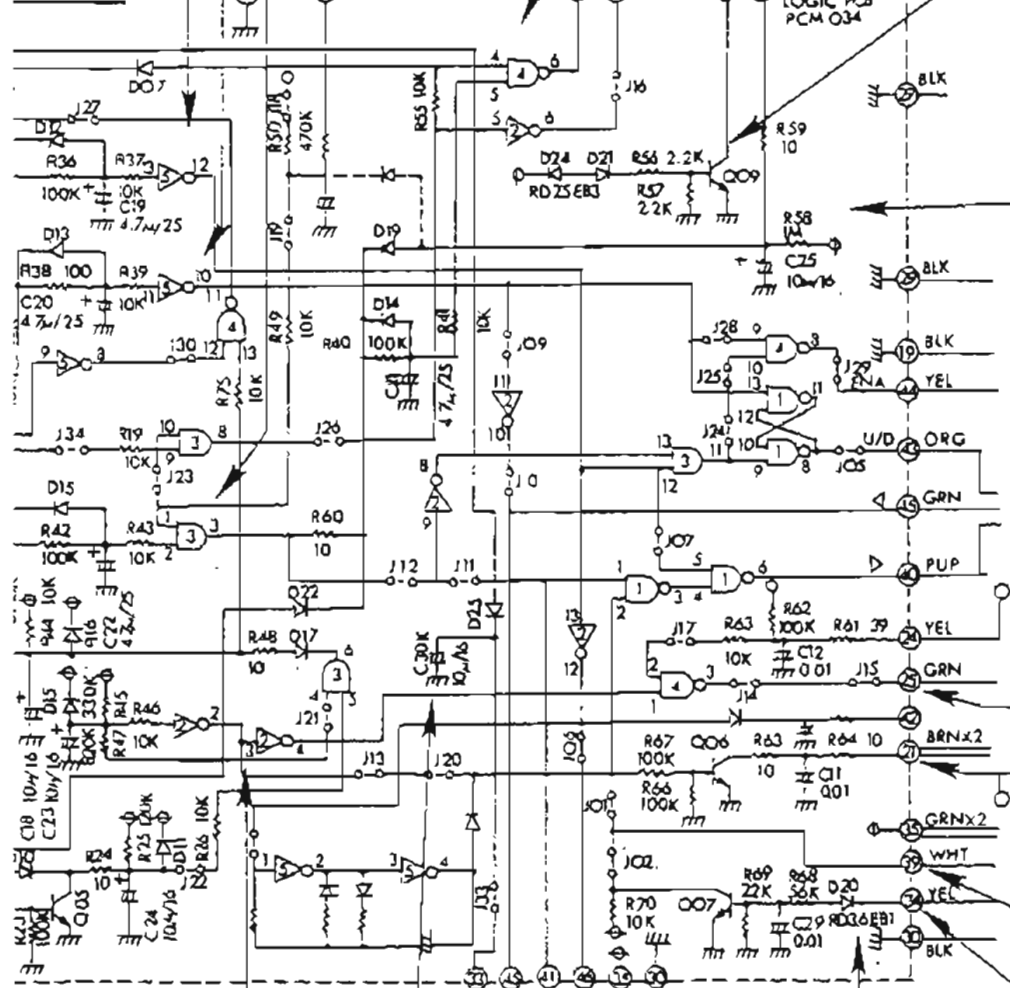

OUT
 -IN
 SW

Power ON Timer

When the power switch is on, the power-on timer functions as follows:

- (1) Holds IC6 INH input in "L" for 4 sec. and inhibits output.
- [Note] Keystrokes are stored in memory.
- (2) Resets the counter.
- (3) Resets the meter.

When REC + STOP, the fall of "H" level is maintained for 0.2 sec.

PLAY output signal

REW output signal

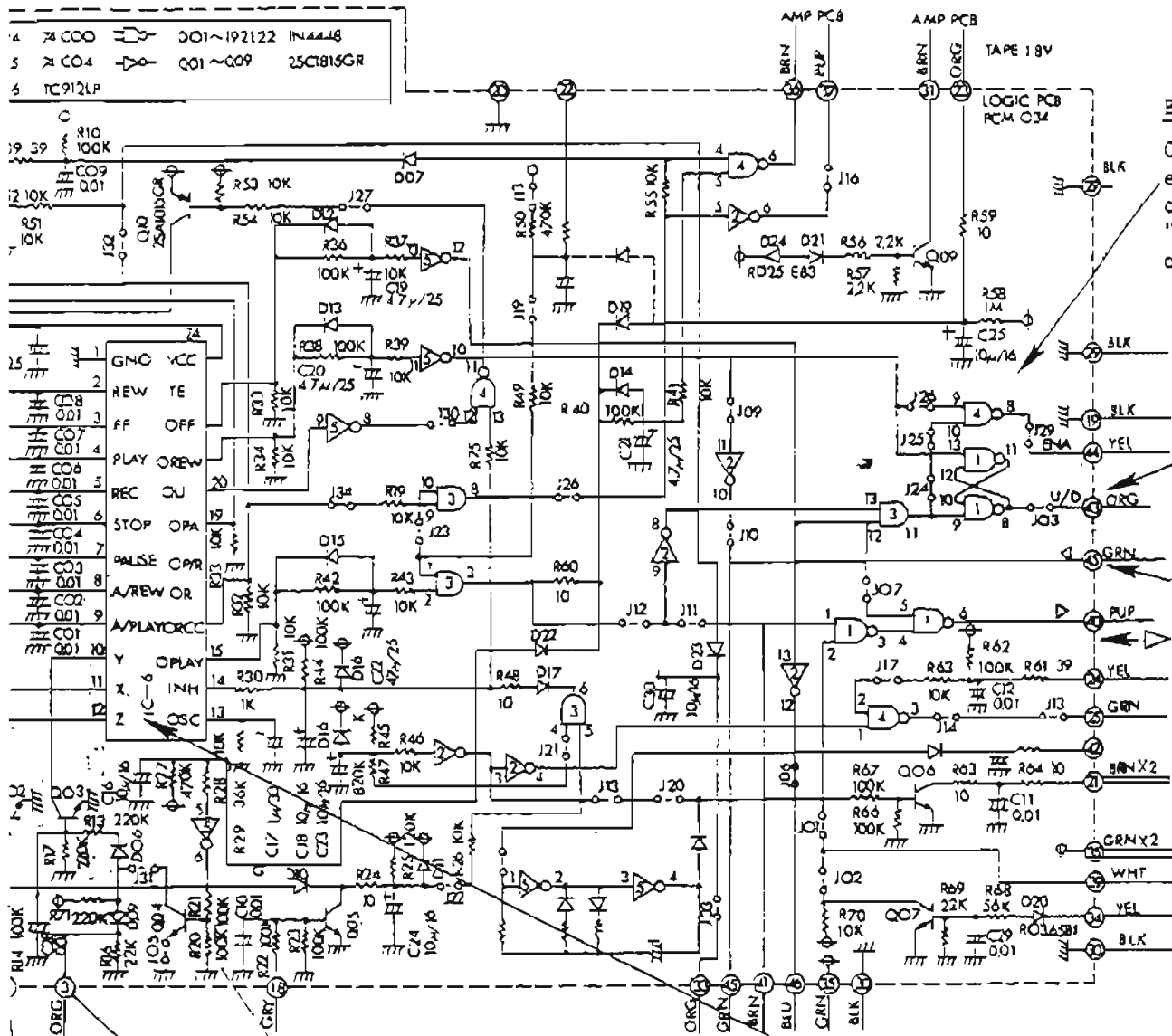

Enable

Controls the tape end output from the counter, and is kept "H" in the FF, REW or PLAY mode.

Controls up count and down count. (up in "H" and down in "L".)

Marker Lights up in "H".

Blinks the marker in the PLAY mode, and lights it "H".

Auto REW Inhibit Timer

Inhibits Auto REW input for about 4 seconds after the rise of the PLAY mode.

(1) Tape start ~ Tape end repeat Actuate when \square pulses are applied to the Z input of IC9121P.

(2) Counter zero ~ preset memory repeat Actuates when \square pulses are applied to the X and Y inputs of IC9121P.

PLAY or AUTO/PLAY input counter indicates zero. A square wave pulse is applied in REW mode.

Acts as AUTO/REW input pin when preset memory is in the preset position. The following waveform is applied to the input in the PLAY/REC mode.

position

Counter preset position



1-4. Explanation of logic control circuit operation (Fig. 1)

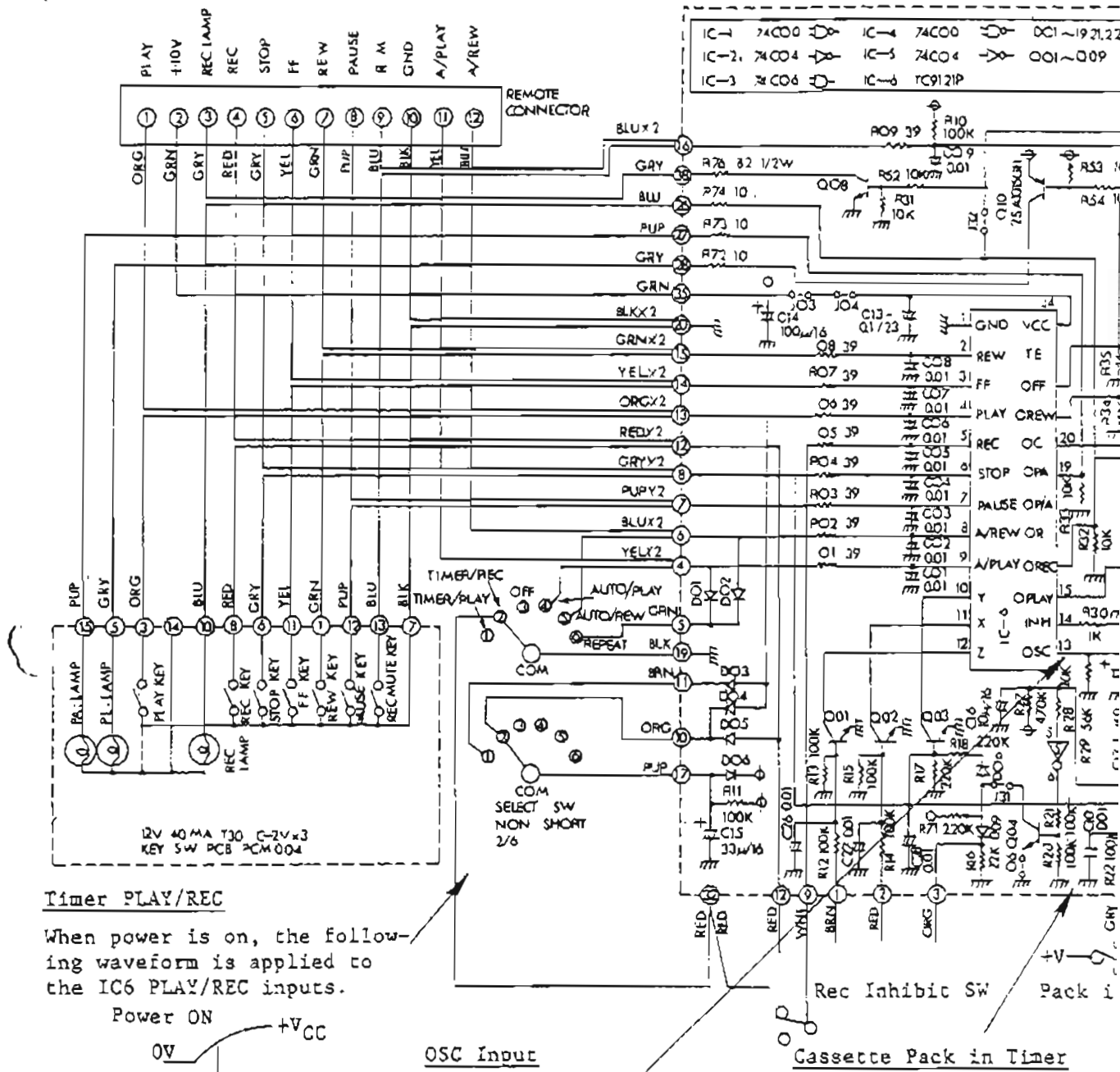

Timer PLAY/REC

When power is on, the following waveform is applied to the IC6 PLAY/REC inputs.

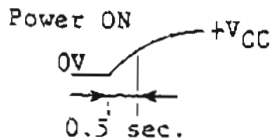

OSC Input

Oscillation waveform for IC6 internal clock is generated at all times.

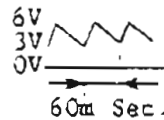

Cassette Pack in Timer

- (1) Holds IC6 INH input in "L" about 1 sec. after cassette half is loaded and inhibits output. [Note] Keystrokes are stored in memory.
- (2) Locks IC6 in the stop when no cassette half loaded.

K-15 BLOCK DIAGRAM

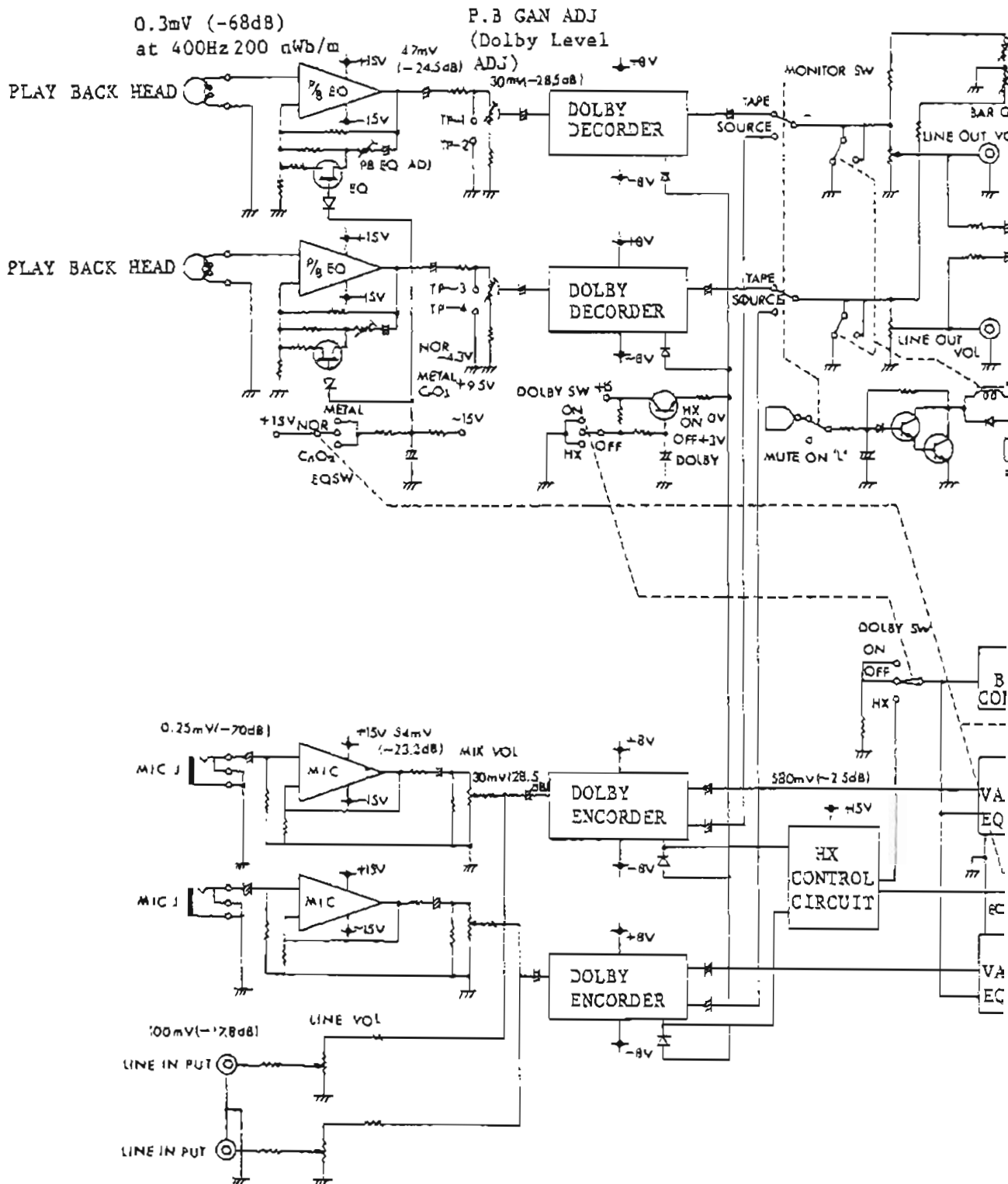

0dB = 0.775V
 Dolby reference level 580mV ±0.5dB

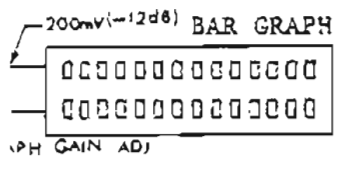

PH OUT
 100mV (-2.5dB)

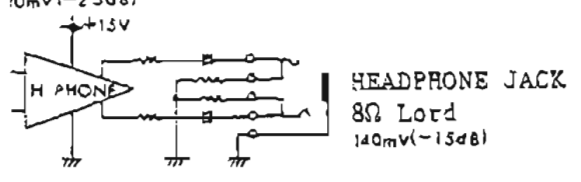

PH OUT
 OFF -12V
 ON +18V



REC ON MUTE 'H'
 (10V)

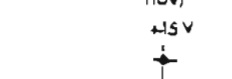

BIAS CONTROL
 MIN +10V
 CENTER +11.5V
 MAX +12.6V

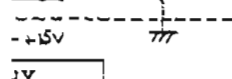

HX LABEL CALIBRATOR
 580mV (-2.5dB)



HX LABEL CALIBRATOR
 -15V

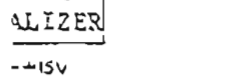

REC MUT ON 'N'



REC MUTE
 ON +14V
 OFF -14V

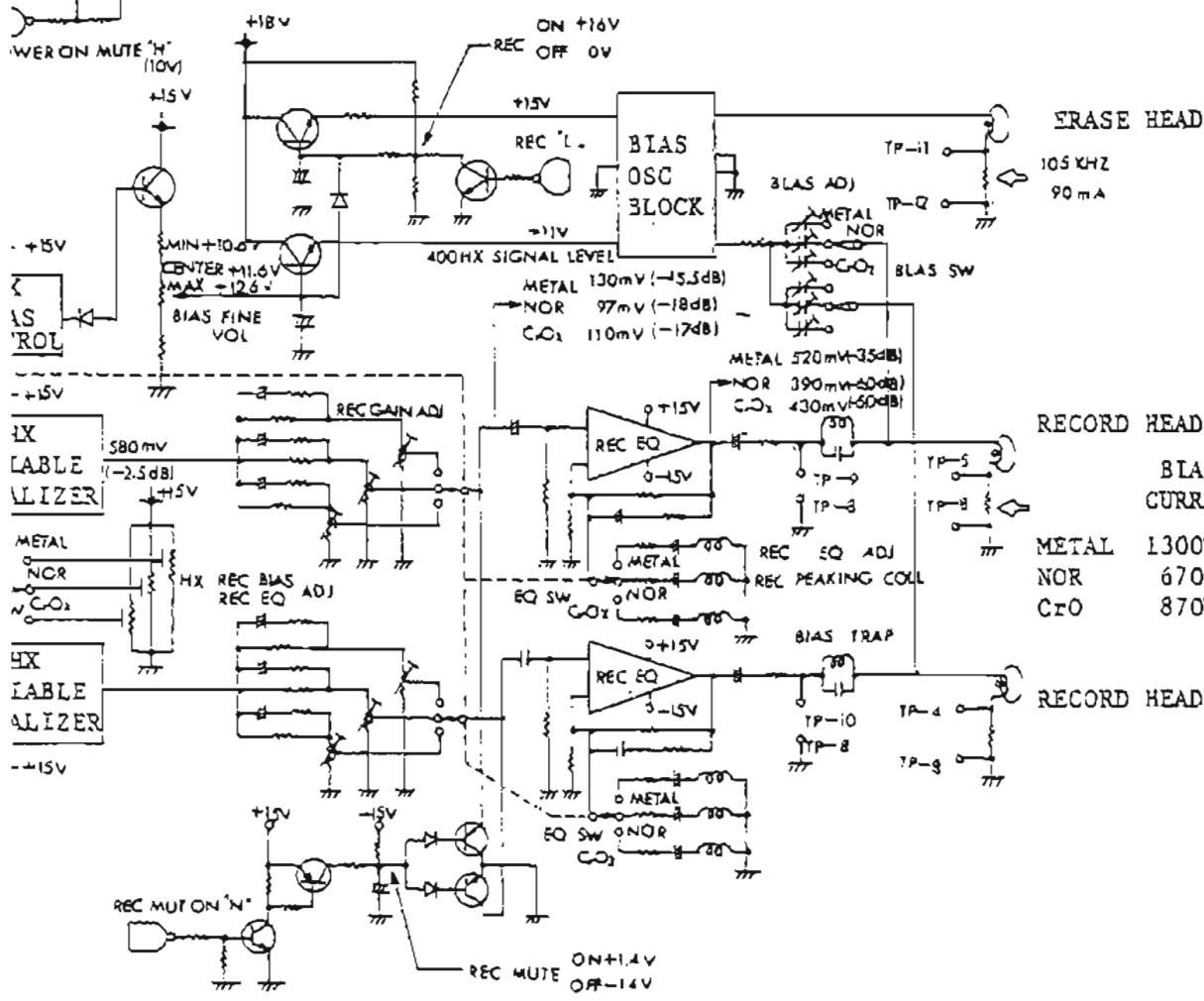

ERASE HEAD

105 KHZ
 90 mA

RECORD HEAD

	BIAS CURRENT	SIGNAL CURRENT at 400Hz
METAL	1300μA	130μA
NOR	670μA	92μA
CrO ₂	870μA	110μA

RECORD HEAD

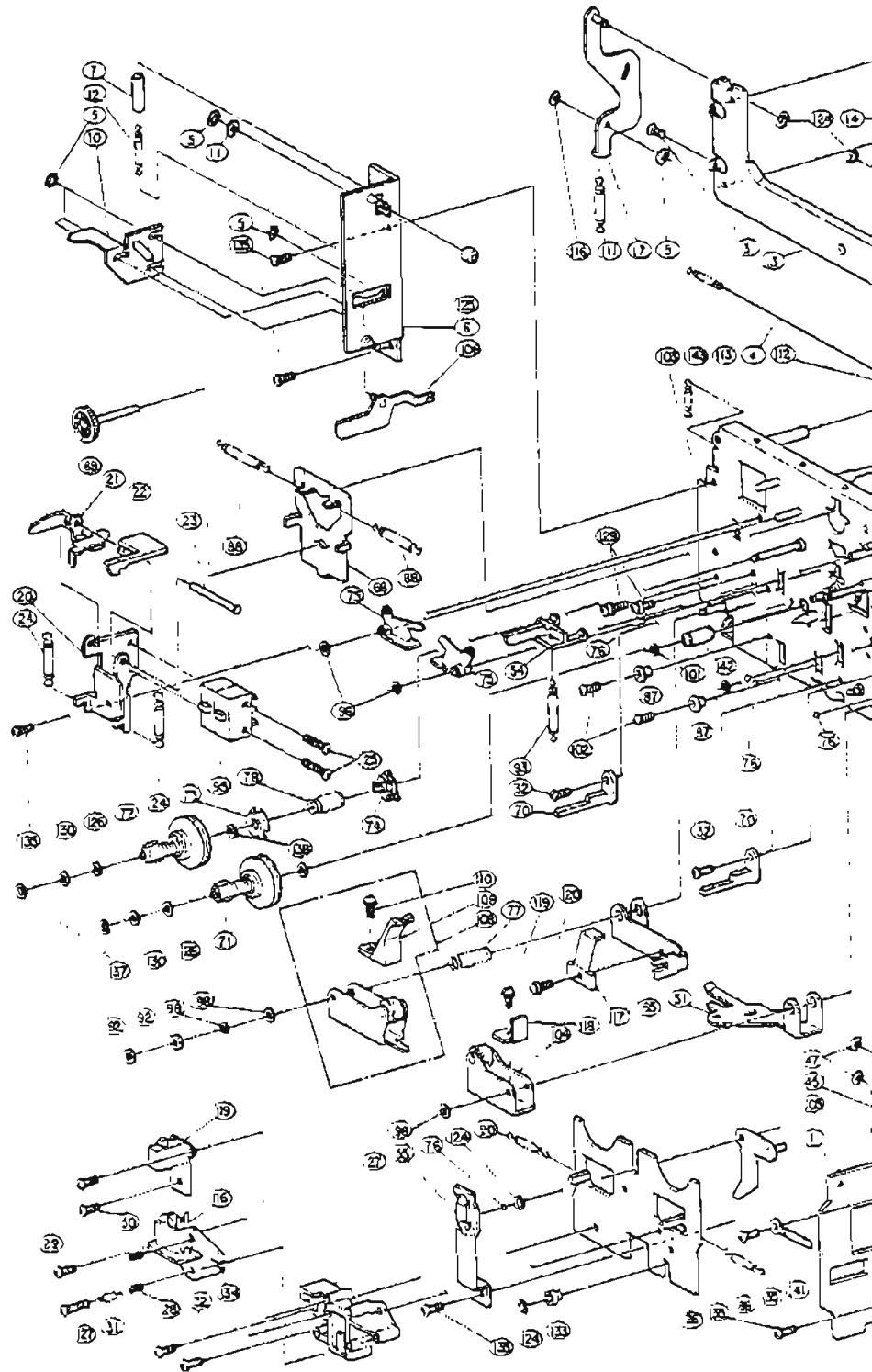

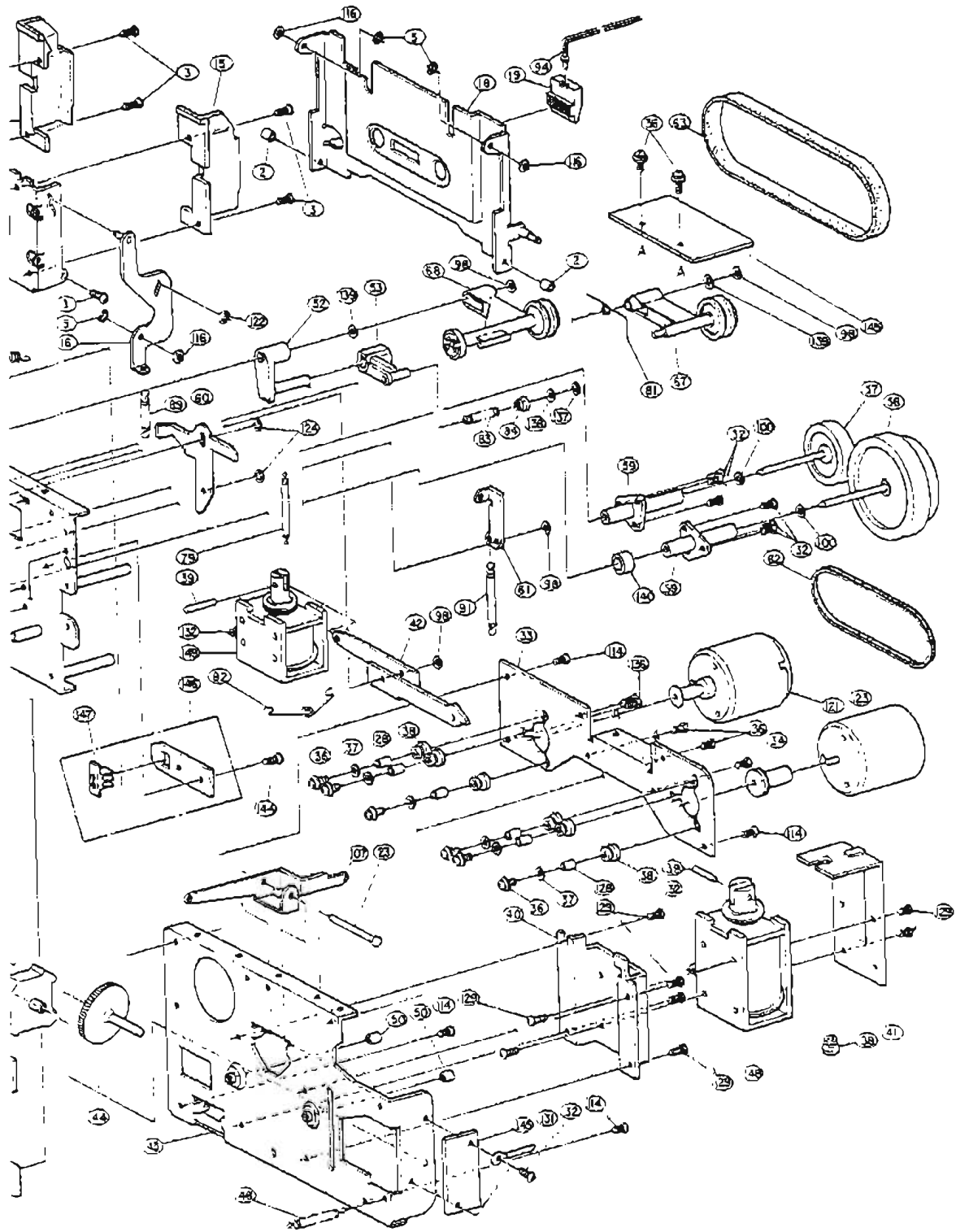

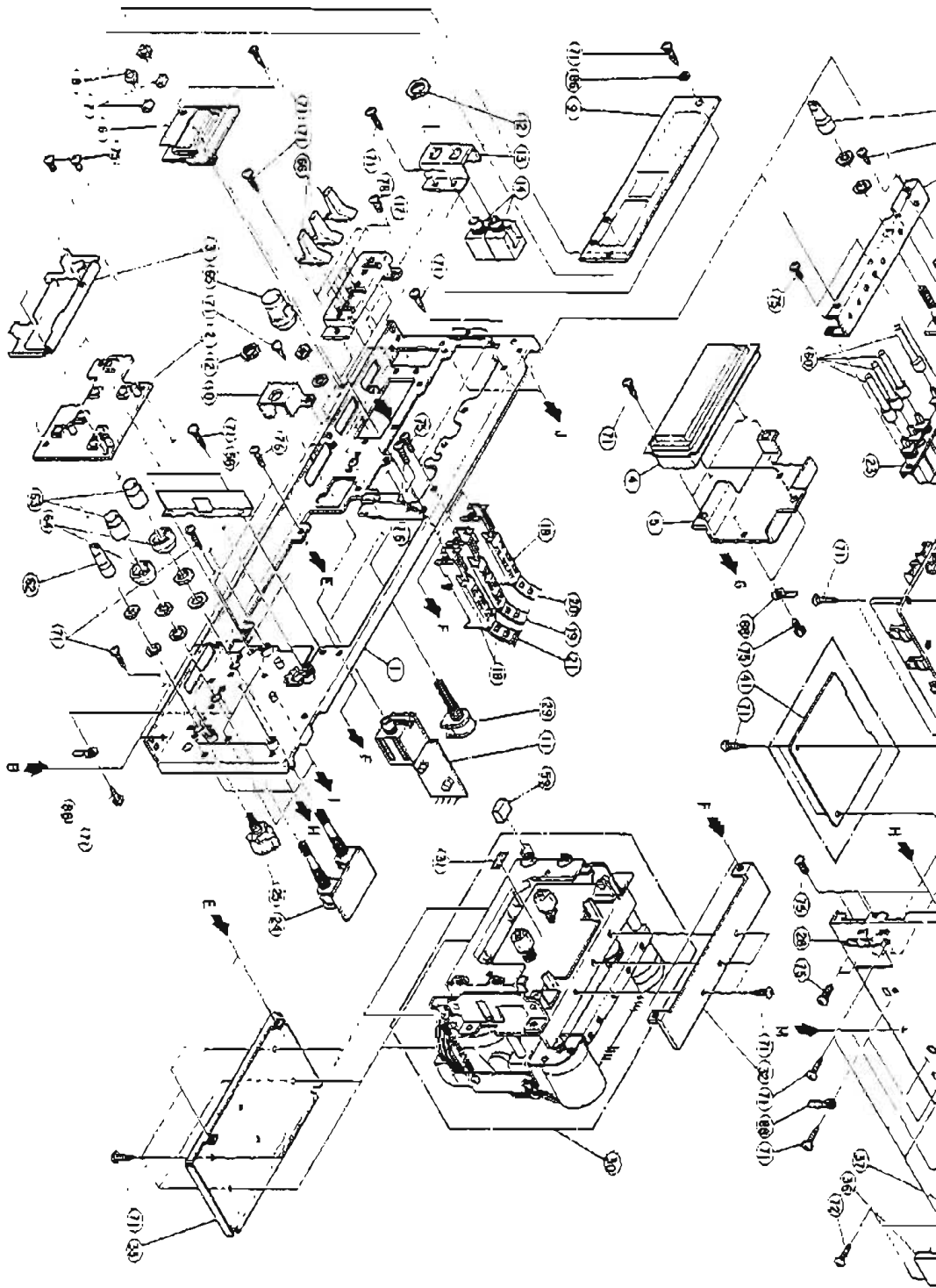

K-18 1979 12

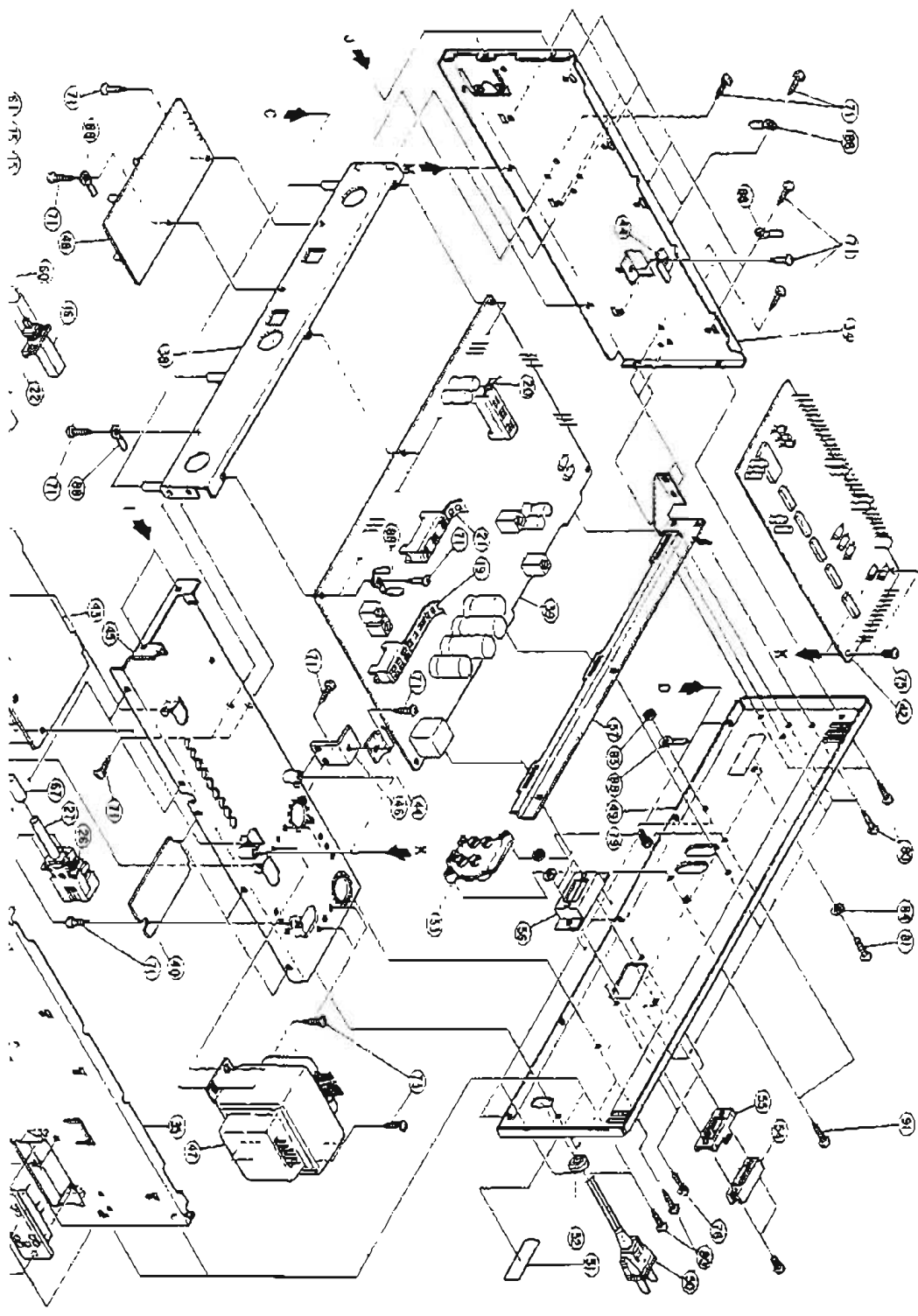

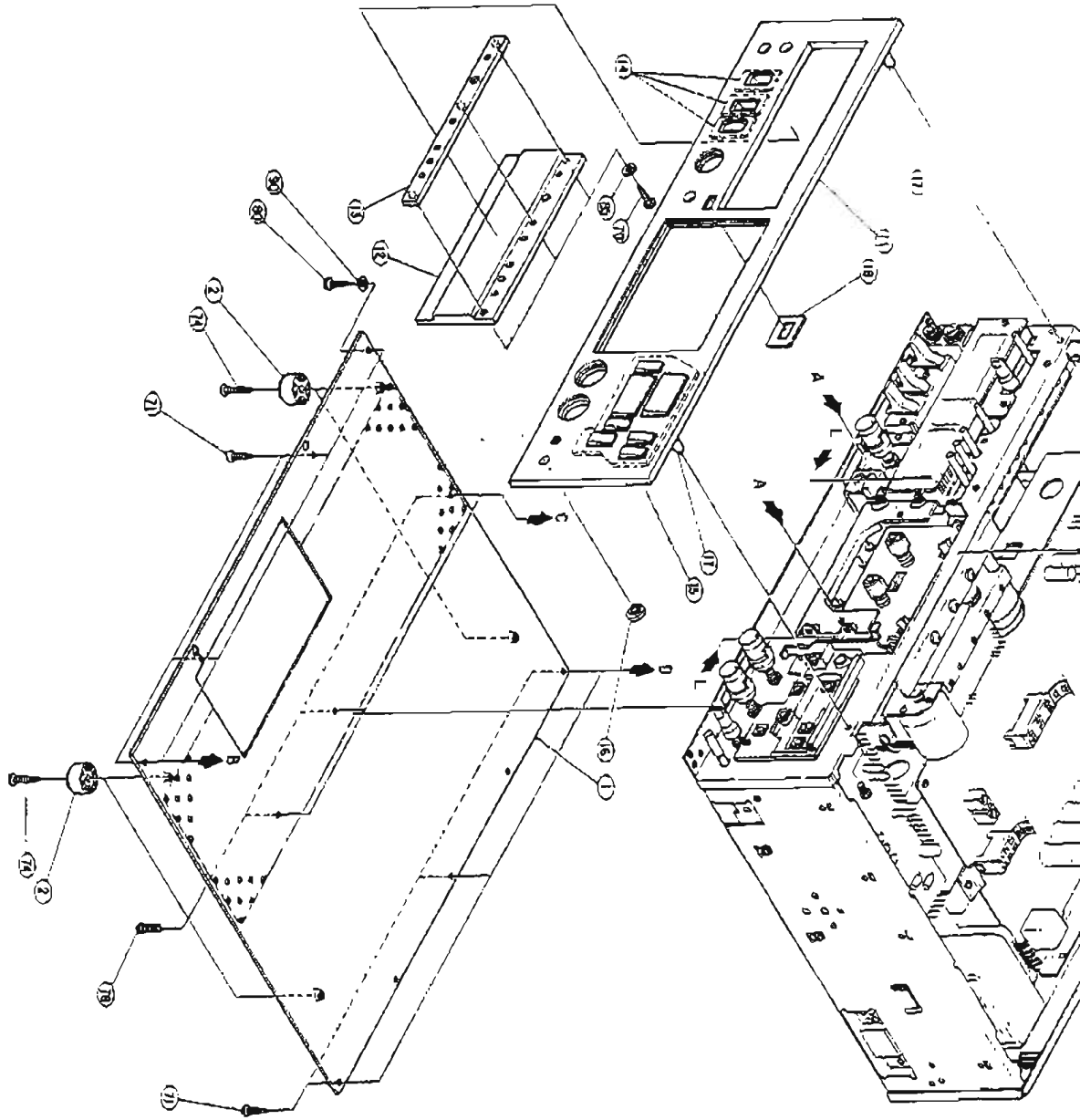

2-18 1979 11

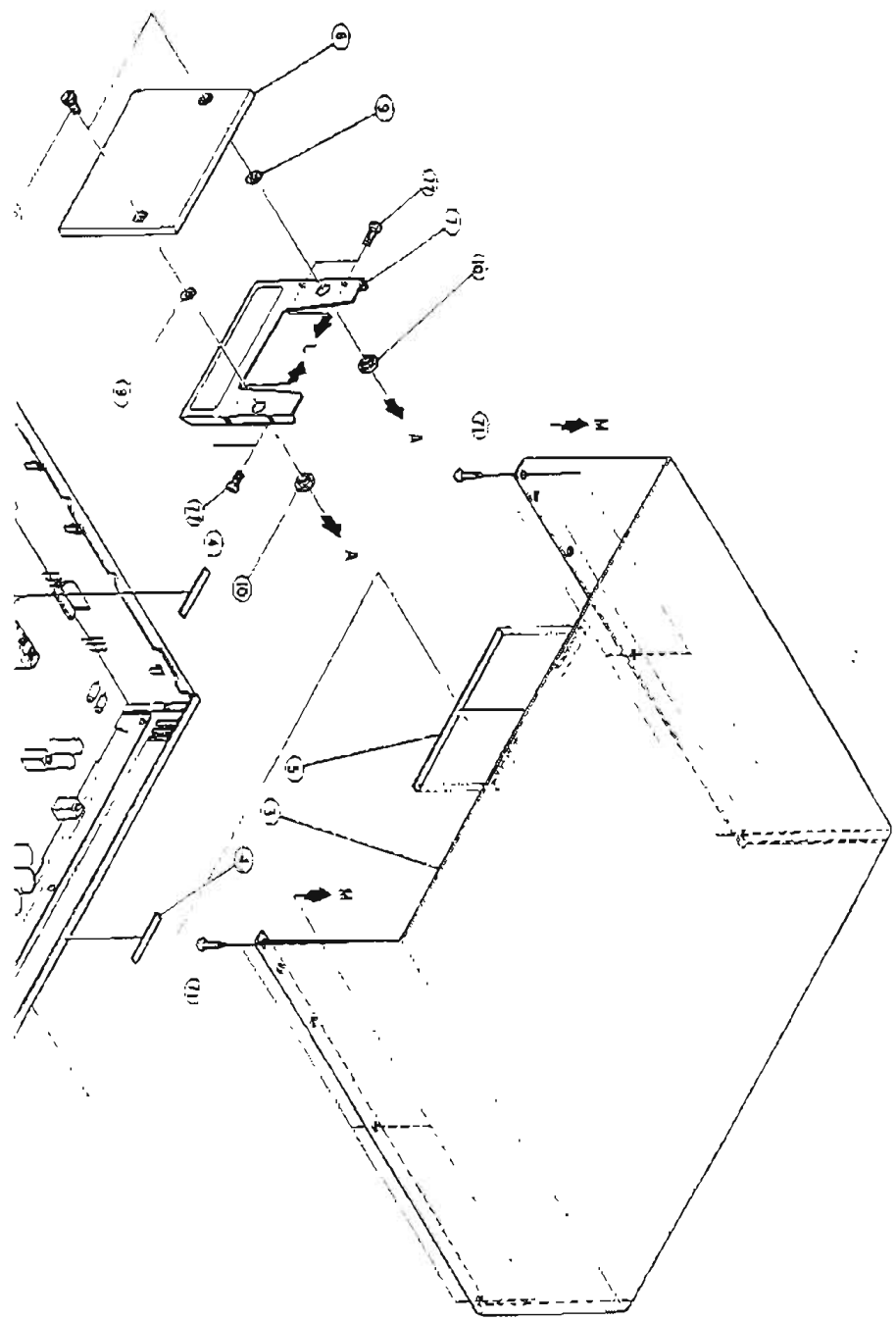

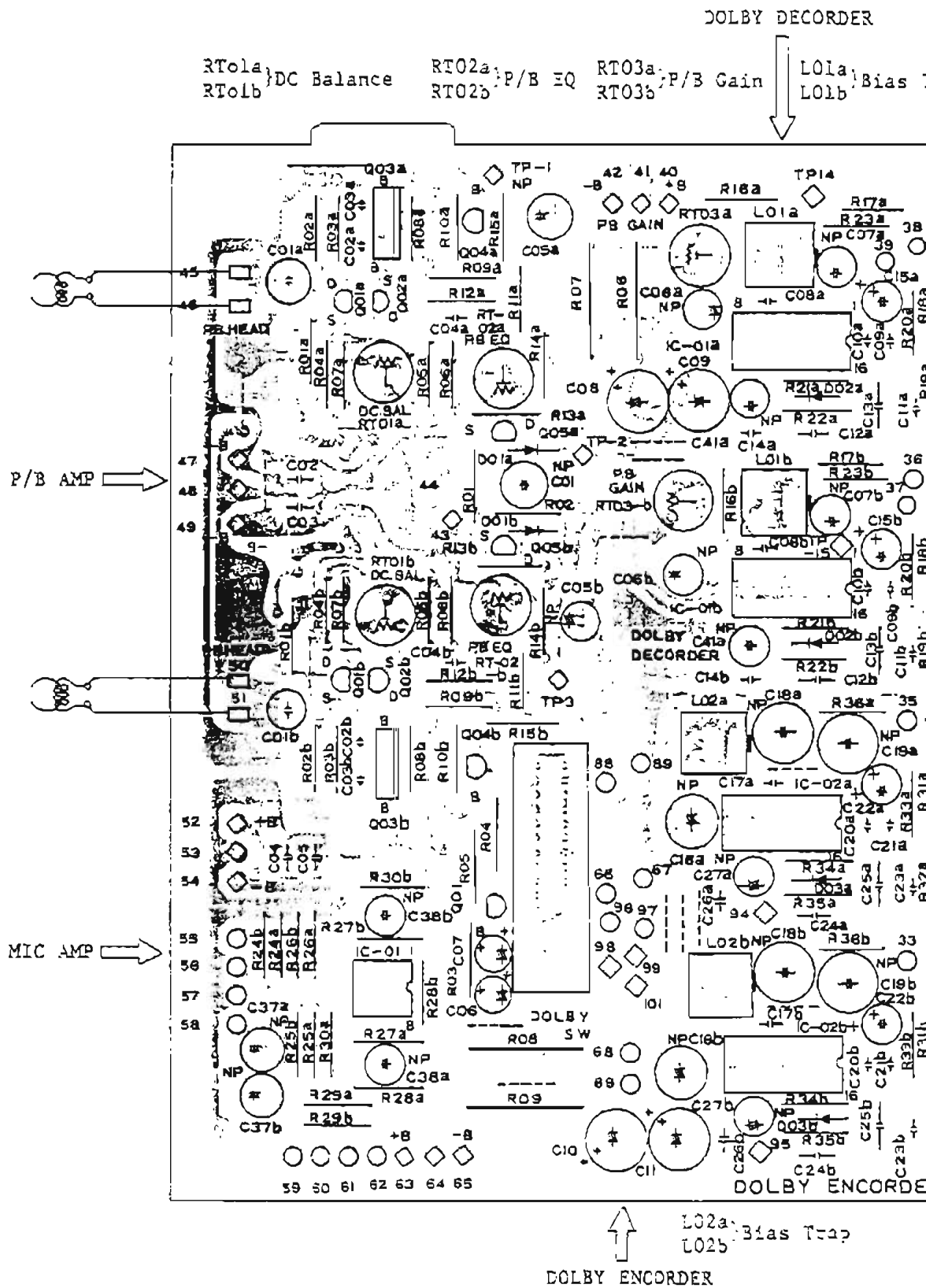

POWER SUPPLY

ap RT04a Meter Adj.
RT04b

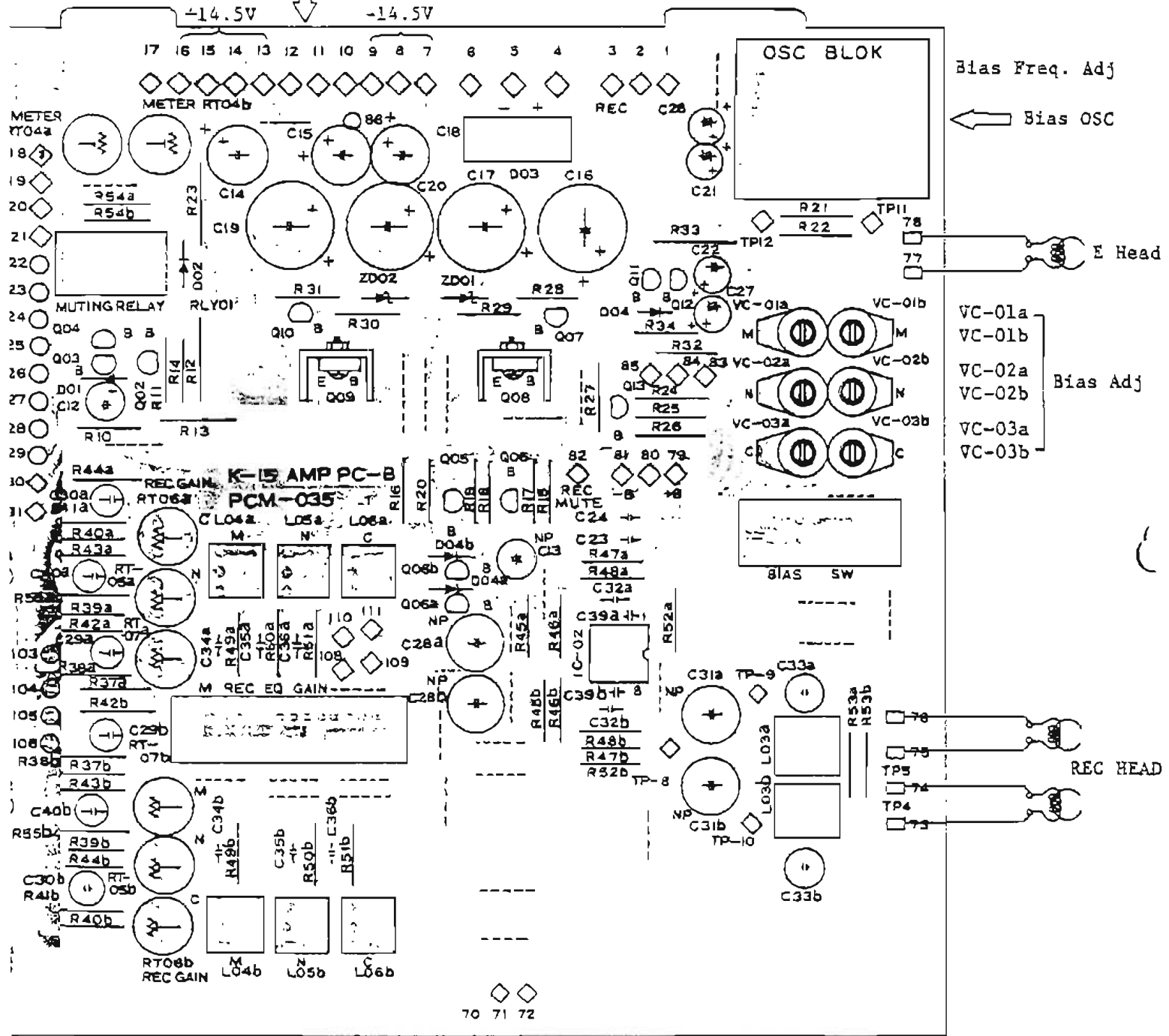

RT06a RT06b
RT05a RT05b
RT07a RT07b
Recording Gain

L04a L05a L06a
L04b L05b L06b
Recording EQ REC AMP

L03a L03b
Bias Trap

POWER SUPPLY

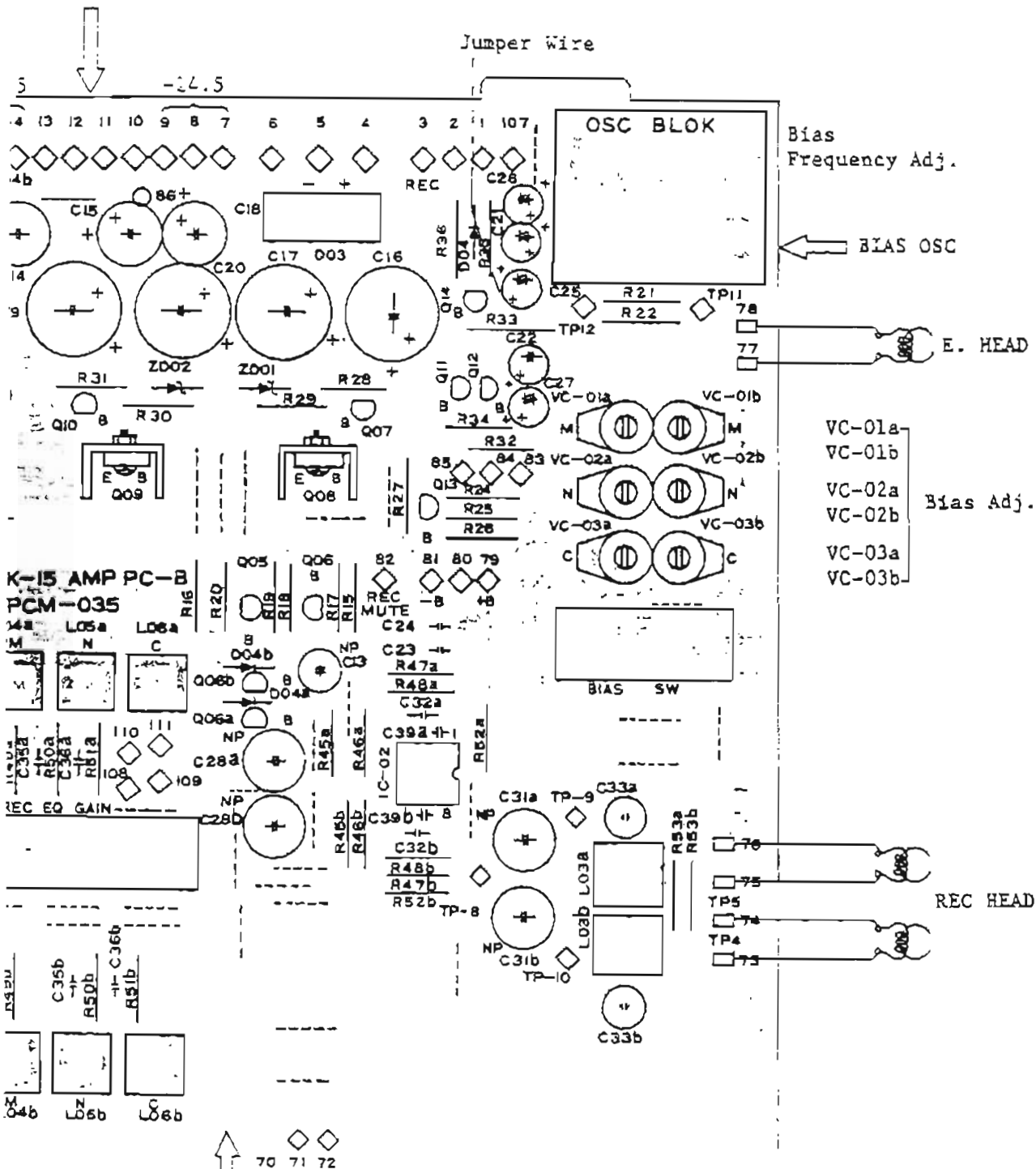

L04a L05a L06a
 L04b L05b L06b

REC AMP

L03a Bias Trap
 L03b

Recording EQ

RT01a) DC. Balance
RT01b)

RT02a) P/B Gain
RT02b)

RT03a) P/B Gain
RT03b)

L01a) Bias Trap
L01b)

RT04a) Meter Ad.
RT04b)

DOLBY DECODER

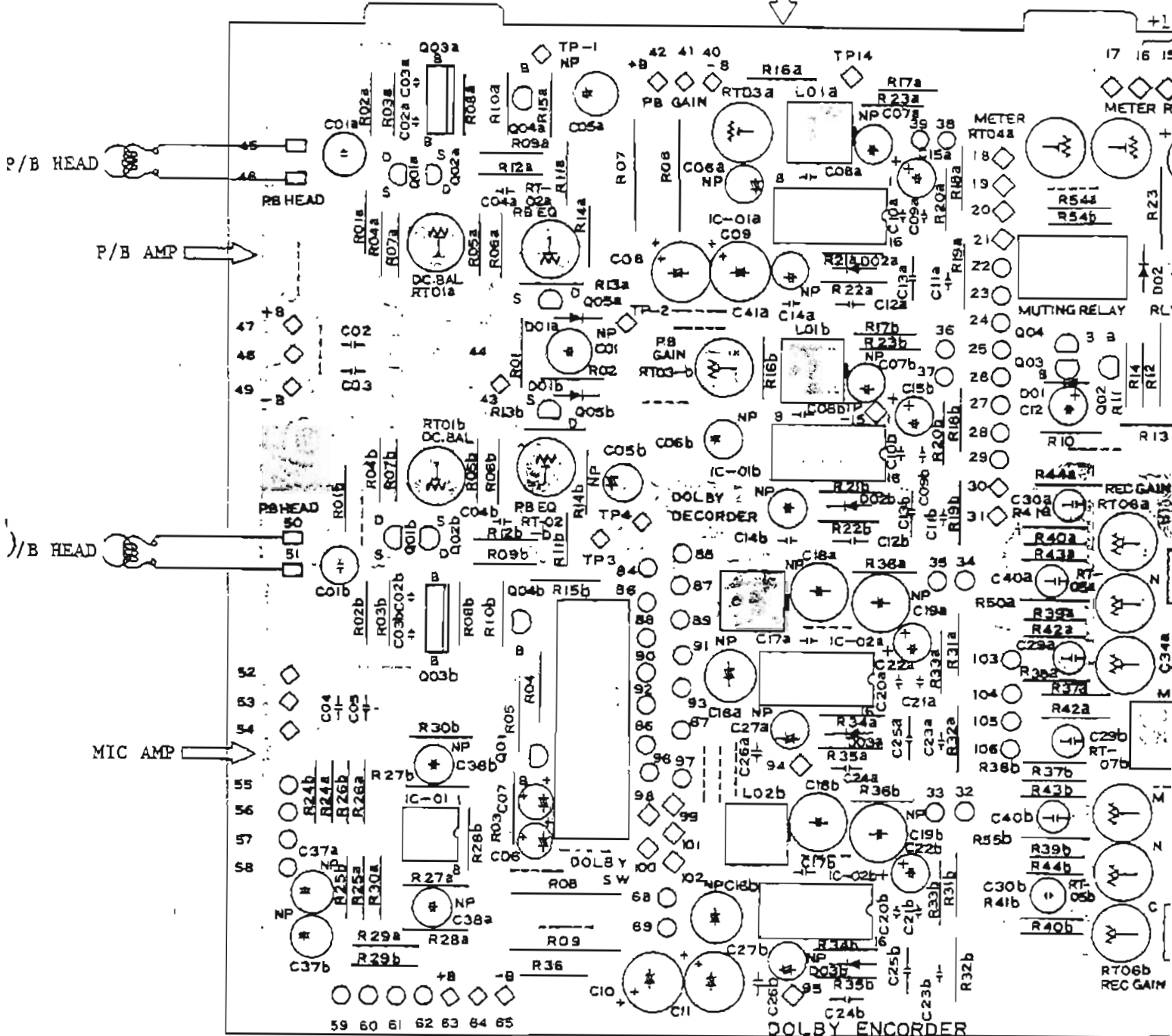

L02a) Bias Trap
L02b)
DOLBY ENCODER

RT06a RT06b
RT05a RT05b
RT07a RT07b

Recording Gain

LUX CORPORATION, JAPAN

1-1, 1-CHOME, SHINSENRI-NISHIMACHI, TOYONAKA-SHI, OSAKA
PHONES: 06-834-2222 CABLE: LUXMAN TOYONAKA TELEX: J6369